

Emergency Vehicle Technician Certification Program



Presented by: A.J. Morganelli
Morganelli & Associates,
Representing:



Emergency Vehicle Technician Training



Basic Electricity

- The interaction of atoms enables electricity
- All matter is made up of atoms
- Atoms are comprised of a nucleus and electrons
- The nucleus is made up of neutral (neutrons) and positive (protons) particles
- Electrons (negative) circle the nucleus

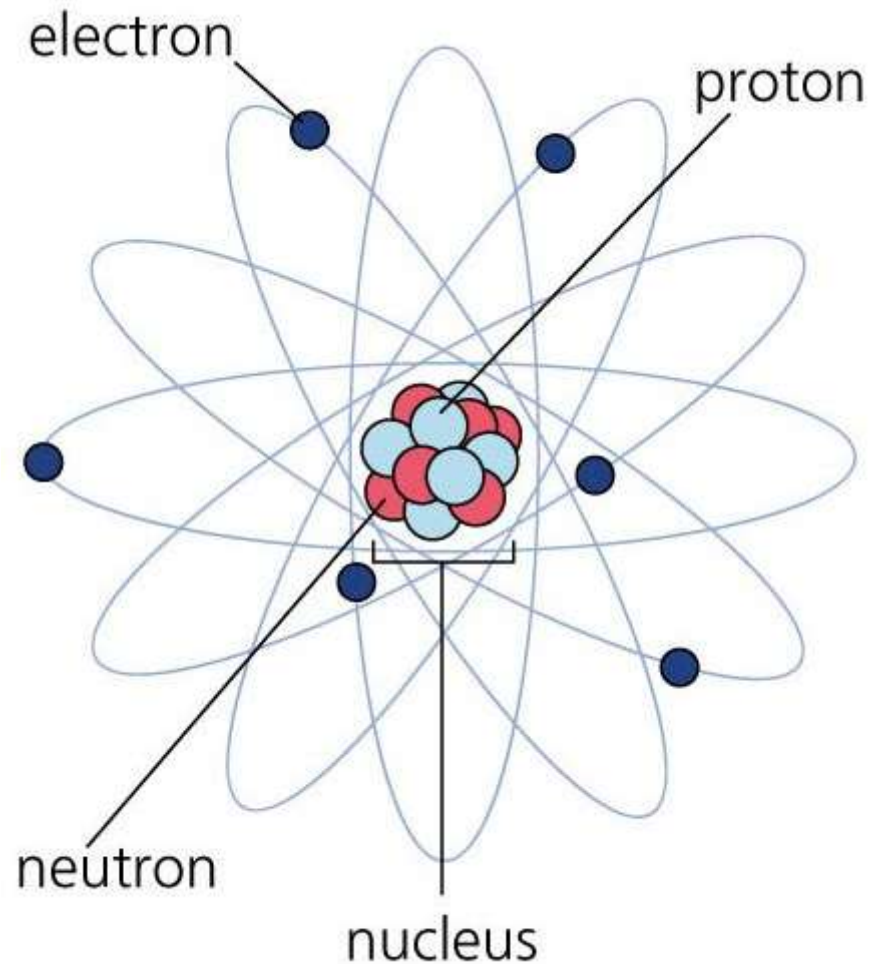

Basic Electricity

- Electrons are pulled from one atom to another to maintain balance
- This movement or flow of electrons creates electrical current
- Current is the measurement of the number of electrons passing a point per second
- Current is measured in amperes (amps)



Basic Electricity

- In a poor conductor, electrons are tight and movement is inhibited
- This inhibition of electrons is called resistance
- Resistance is measured in ohms (Georg Simon Ohm 1800's)
- The flow of electricity is described in terms of voltage, current and resistance
- Voltage = force or pressure required to move electrons through a circuit (volts) Alessandro Volta 1800



Basic Electricity

- Current is the flow or movement of electric charge
- If more voltage is applied more electrons are pushed through a circuit
- Resistance is the degree to which current flow is held back, measured in ohms
- Increasing resistance in a circuit while maintaining a steady voltage decreases the amount of current flow



Definitions & Terms

- **LED** = Light Emitting Diode
- **GPS** = Global Position System
- **SIR/SRS** = Air Bag = Supplemental Inflatable Restraint, Supplemental Restraint System
- **Wig-wags** = Alternating Flashing Head Lights
- **R.F.I.** = Radio Frequency Interference
- **Traffic Pre-emptive System** = OPTICOM
- **Ohm's Law** = Relationship Between Voltage, Electric Current, and Resistance in an Electric Circuit.



Definitions & Terms

- **LoJack** = Stolen vehicle recovery system
- **Strobes** = high voltage gaseous discharge flash tube, System made up of power supply, cable, flash tube
- **ABS** = Anti lock brake system
- **Voltage Drop** = loss of voltage caused by resistance
- **LCD** = Liquid Crystal Display
- **Wire Gauge** = (AWG American Wire Gauge) smaller the number larger the wire
- **Impedance** = Resistance



Definitions & Terms

- **DMM** = Digital Multi-Meter
- **CCA** = Cold Cranking Amps
- **Memory Saver Device** = 9 vdc battery with cig plug
- **IOD**= Ignition Off Draw
- **HZ** = Hertz
- **SAE** = Society of Automotive Engineers
- **Convolute** = Split Loom
- **4WAL** = Four Wheel Anti-Lock Brake
- **TPMS** = Tire Pressure Monitoring System



Ohm's Law

- Ohm's Law is based on the fact that in a DC circuit one volt across a one watt resistor will cause one amp of current to pass through the resistor at one watt of power.
- **E = Volts**
- **I = Current**
- **R = Resistance**
- **P = Watts**



Ohm's Law

- $P=I(E)$ or Power = Current x Voltage
- Or more easily:

WATTS = AMPS x VOLTS

and

AMPS = WATTS / VOLTS



P = Watts

$$\text{Watts} = \frac{\text{Volts}^2}{\text{Ohms}}$$

$$\text{Watts} = \text{Amperes}^2 \times \text{Ohms}$$

$$\text{Watts} = \text{Volts} \times \text{Amperes}$$

I = Amperes

$$\text{Amperes} = \frac{\text{Volts}}{\text{Ohms}}$$

$$\text{Amperes} = \frac{\text{Watts}}{\text{Volts}}$$

$$\text{Amperes} = \sqrt{\frac{\text{Watts}}{\text{Ohms}}}$$

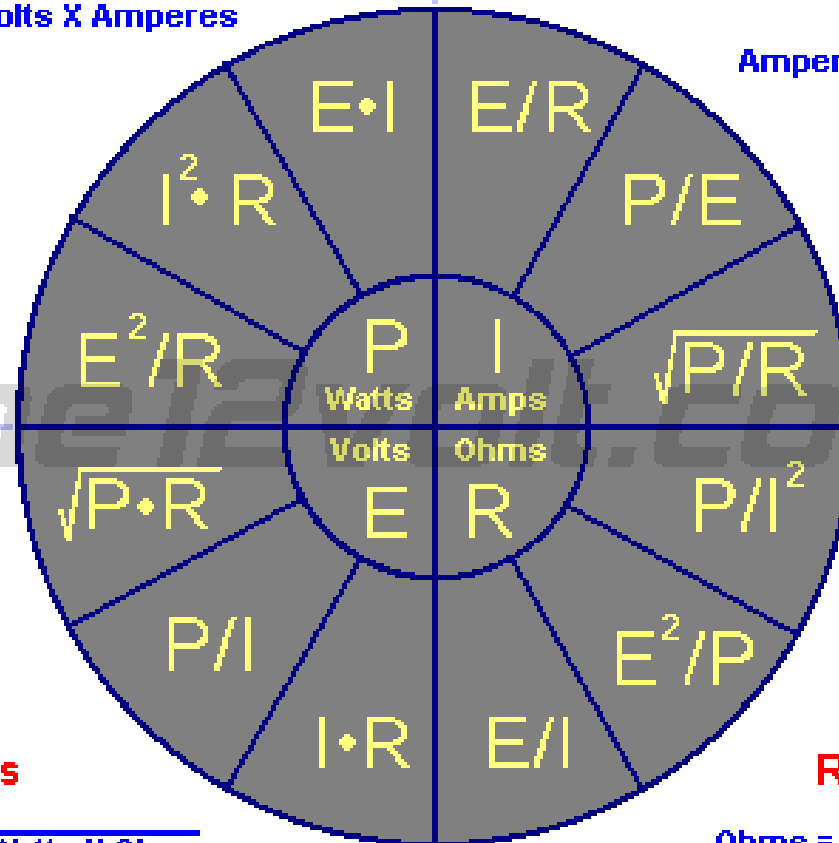

E = Volts

$$\text{Volts} = \sqrt{\text{Watts} \times \text{Ohms}}$$

$$\text{Volts} = \frac{\text{Watts}}{\text{Amperes}}$$

$$\text{Volts} = \text{Amperes} \times \text{Ohms}$$

R = Ohms

$$\text{Ohms} = \frac{\text{Volts}}{\text{Amperes}}$$

$$\text{Ohms} = \frac{\text{Volts}^2}{\text{Watts}}$$

$$\text{Ohms} = \frac{\text{Watts}}{\text{Amperes}^2}$$



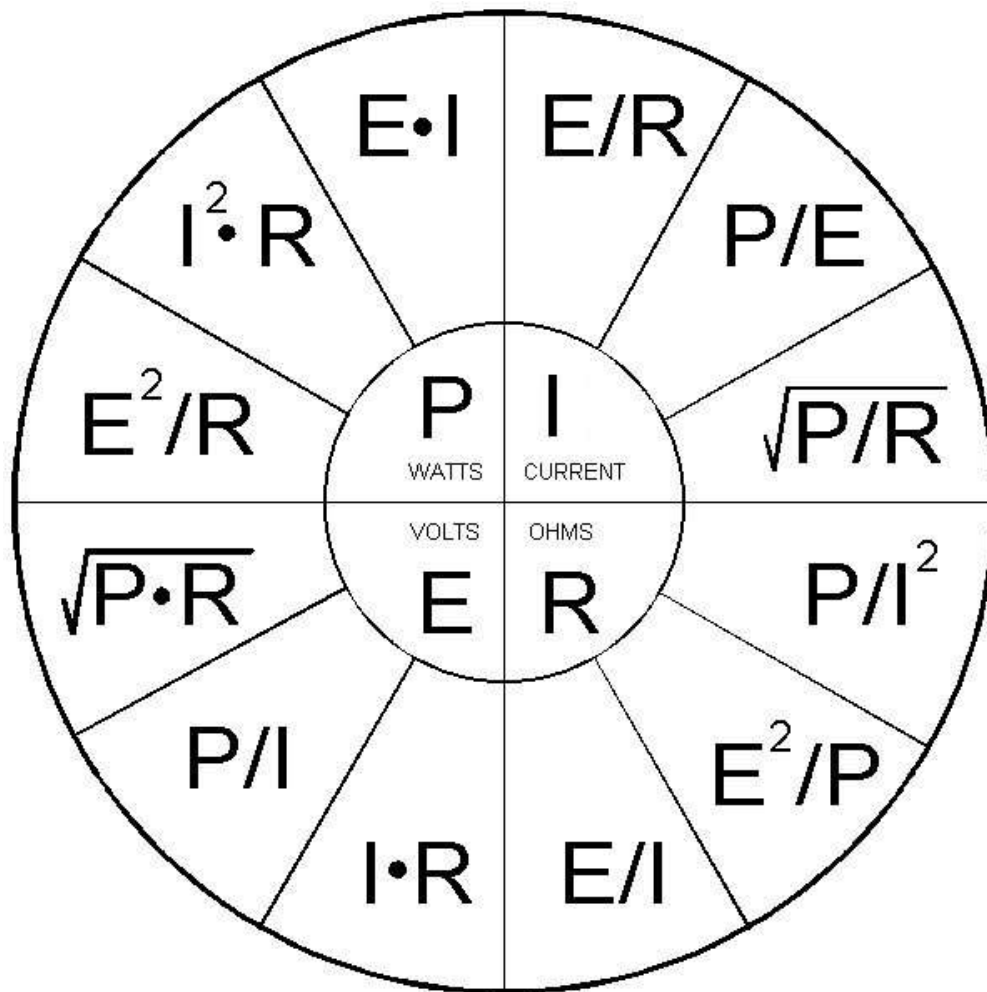

Volts = Amps X Resistance

Volts = Watts / Amps

Volts = Square Root of (Watts X Resistance)

Amps = Volts / Resistance

Amps = Watts / Volts

Amps = Square Root of (Watts / Resistance)

Resistance = Volts / Amps

Resistance = Volts X Volts / Watts

Resistance = Watts / (Amps X Amps)

Watts = Volts X Amps

Watts = Amps X Amps X Resistance

Watts = Volts X Volts / Resistance



Ohm's Law

- In a 12vdc circuit what is the amp draw for each item and what gauge wire should be used for a 20 foot length for each item.
- Power Supply = 75 watts = 6.25 amps
- Siren = 110 watts = 9.17 amps
- Light Bar = 120 watts = 10 amps
- Total watts = 305 watts
- Amp Draw = 25.42



Wire Gauge Calculation Chart

Maximum Current Draw Through The Wire

Wire Gauge	5 Amps	10 Amps	15 Amps	20 Amps	25 Amps	30 Amps	35 Amps	40 Amps	
	22 AWG	6 Feet	3 Feet	Insufficient	Insufficient	Insufficient	Insufficient	Insufficient	Insufficient
	20 AWG	9.5 Feet	5 Feet	3 Feet	Insufficient	Insufficient	Insufficient	Insufficient	Insufficient
	18 AWG	15 Feet	7.5 Feet	5 Feet	4 Feet	3 Feet	Insufficient	Insufficient	Insufficient
	16 AWG	24.5 Feet	12 Feet	8 Feet	6 Feet	5 Feet	4 Feet	3.5 Feet	3 Feet
	14 AWG	39 Feet	19.5 Feet	13 Feet	9.5 Feet	8 Feet	6.5 Feet	5.5 Feet	5 Feet
	12 AWG	62 Feet	31 Feet	20.5 Feet	15.5 Feet	12.5 Feet	10.5 Feet	9 Feet	7.5 Feet
	10 AWG	98 Feet	49 Feet	32.5 Feet	24.5 Feet	19.5 Feet	16.5 Feet	14 Feet	12.5 Feet
	8 AWG	156 Feet	78 Feet	52 Feet	39 Feet	31 Feet	26 Feet	22.5 Feet	19.5 Feet
	6 AWG	248.5 Feet	124 Feet	82.5 Feet	62 Feet	49.5 Feet	41.5 Feet	35.5 Feet	31 Feet
4 AWG	395 Feet	197.5 Feet	131 Feet	98.5 Feet	79 Feet	66 Feet	56.5 Feet	49.5 Feet	
2 AWG	629 Feet	314 Feet	209 Feet	157 Feet	125.5 Feet	104.5 Feet	89.5 Feet	78.5 Feet	



Kirchhoff's Current Law 1845

- "The algebraic sum of all currents entering and exiting a node must equal zero"
 - At any point in an electrical circuit where charge density is not changing in time, the sum of currents flowing towards that point is equal to the sum of currents flowing away from that point.



Kirchhoff's Voltage Law

- "The algebraic sum of the voltage drops in any closed path in a circuit and the electromotive forces in that path is equal to zero."

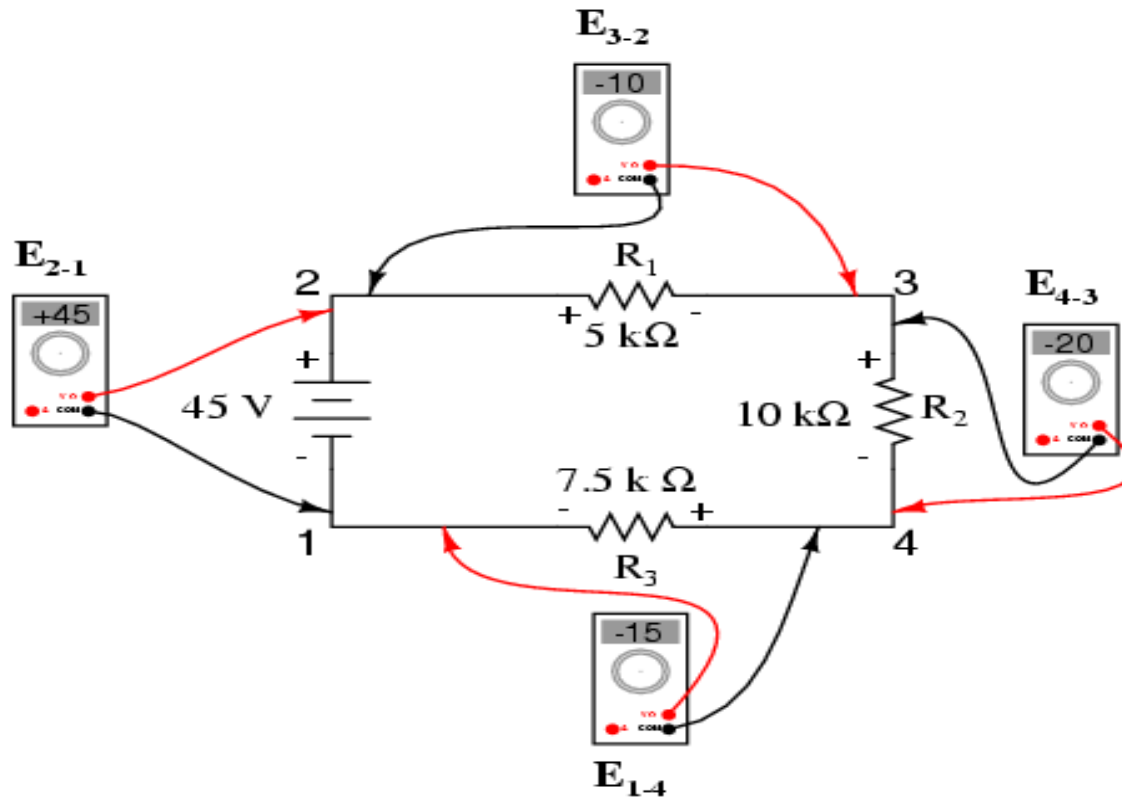

Series Circuits

Resistors can be connected in series; that is, the current flows through them one after another. The circuit in Figure 1 shows three resistors connected in series, and the direction of current is indicated by the arrow.

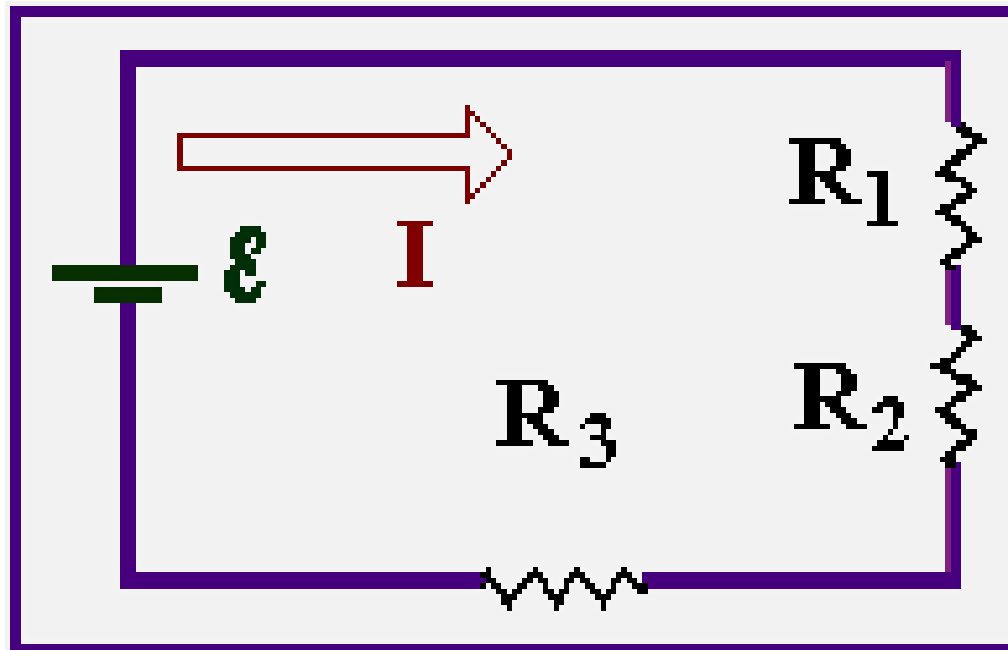

A **parallel circuit** has more than one resistor (*anything that uses electricity to do work*) and gets its name from having multiple (**parallel**) paths to move along.

Charges can move through any of several paths. If one of the items in the circuit is broken then no charge will move through that path, but other paths will continue to have charges flow through them.

Parallel circuits are found in most household electrical wiring. This is done so that lights don't stop working just because you turned your TV off.



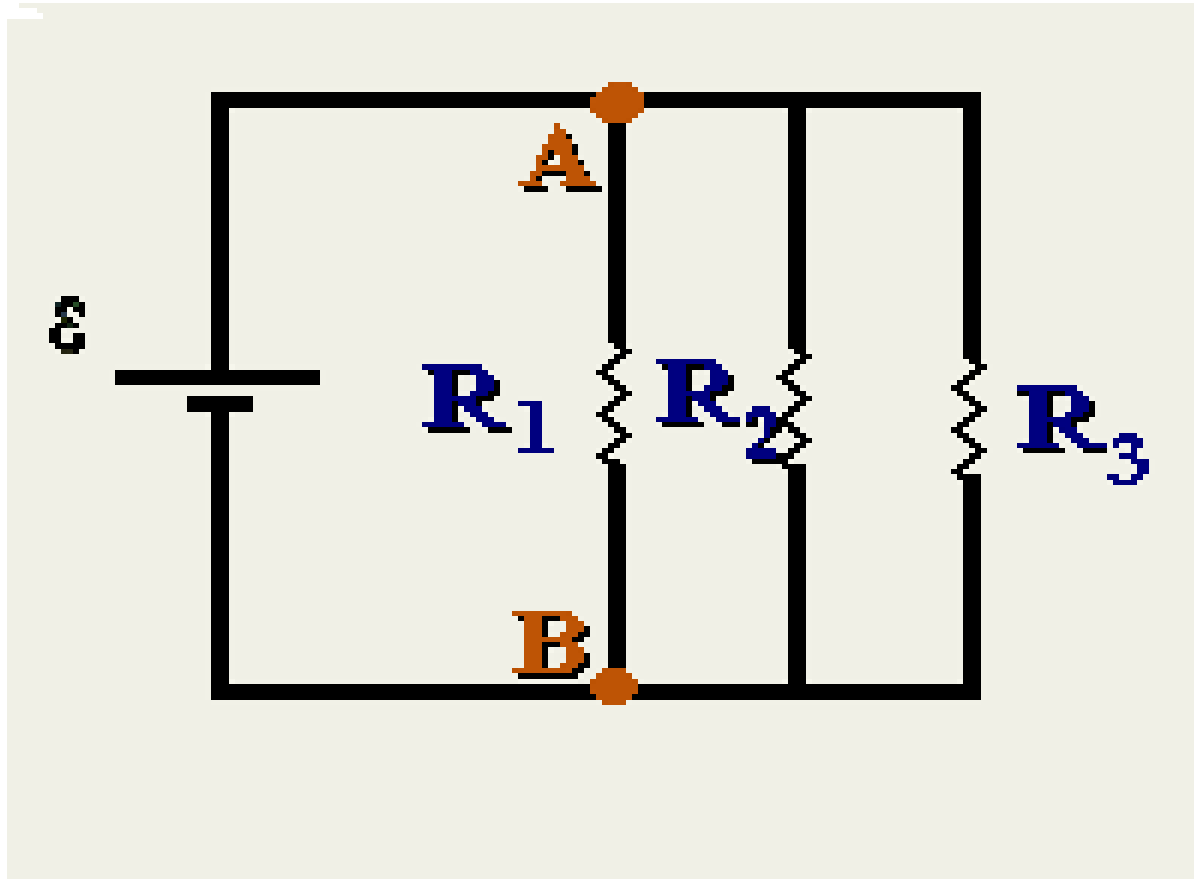

Circuit containing resistors in parallel

Battery Safety

- Batteries give off Hydrogen gas
- Sparks can ignite the gas and explode
- Exploding gas inside the battery can cause severe acid burns or blindness
- Removing the negative battery cable can cause a spark due to live circuits collapsing
- Properly connect the jumper cables



Battery Safety

- **First** attach the (+) positive cable to the dead battery
- **Second** connect the (+) positive cable to the good (booster) battery
- **Third** connect the (-) negative cable to the good (booster) battery
- **Fourth** connect the (-) negative cable to the chassis of the dead vehicle as far a way from the battery as possible on an unpainted spot



Battery Safety

- Use a carry strap or battery carrier
- Dropping a battery can cause acid to splash in your eyes
- Wear safety glasses or goggles
- Remove rings and watches
- Contact from the (+) terminal to ground from rings or watches can cause severe electrical burns



Electrical & Electronic Symbols

- Get your Pad and Pencil Ready



Switches



Switches

- A switch is a device used to make, break, or change an electrical circuit.
- **SPST** Single Pole Single Throw
- **SPDT** Single Pole Double Throw
- **DPST** Double Pole Single Throw
- **DPDT** Double Pole Double Throw
- Momentary



Switches

- High Current
- Low Current
- Serial Control
- Computer Operated Car 54 Project
- Remote Radio Frequency



Control Modules / Switches



Control Modules / Switches

- CONTROL MODULES / SWITCH BOXES
- SLIDE (PROGRESSIVE SLIDE) SWITCH
 - Visibly recognizable, usually three-position
 - Adds circuits as the switch is progressed through the steps.

1=1

2=1+2

3=1+2+3



Control Modules / Switches

- DISCONNECTING THE VEHICLE BRAKE LAMP CIRCUIT USING ANY SIRENS WITH RELAY OUTPUTS OR SWITCH CONTROLLERS COULD CAUSE VEHICLE OR PROPERTY DAMAGE, SERIOUS INJURY OR EVEN DEATH.
- DISABLING THIS CIRCUIT IS A VIOLATION OF THE FEDERAL MOTOR VEHICLE SAFETY STANDARD FOR THE THIRD BRAKE LIGHT, AS WELL AS REAR BRAKE LIGHTS. FUNCTIONS THAT BLACK OUT THE REAR BRAKE LIGHTS (SOMETIMES CALLED “BRAKE LIGHT CUT OUT”) MAY INTERFERE WITH THE BRAKE SHIFT LOCK MECHANISM, AND CAUSE THE VEHICLE TO MOVE UNEXPECTEDLY AND DANGEROUSLY.



Control Modules / Switches

- Do not exceed 10A fuse ratings when replacing fuses. Failure to comply may damage the unit.
- When drilling holes in ANY part of the vehicle, ensure that both sides of the surface are clear of parts that could be damaged; such as brake lines, electrical wiring or other vital parts.
- Damage the air bag, or potentially damage or dislodge the equipment, causing serious injury or death to you or others.



Relays

- Electromagnetic Device to Control Large Amounts of Current by The Use of Small Amounts of Current

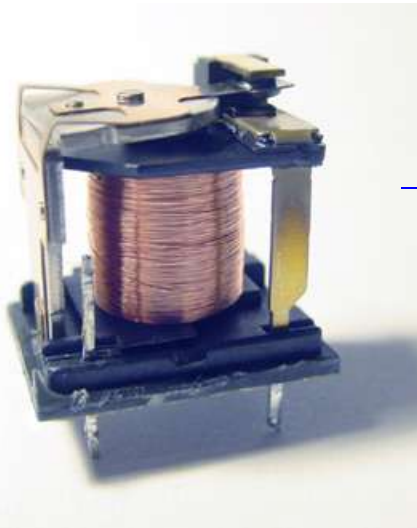

Relays

**Bosch™
Style**

**Horn Ring
Transfer Relay
(Customer Supplied)**

**Generic
Style**

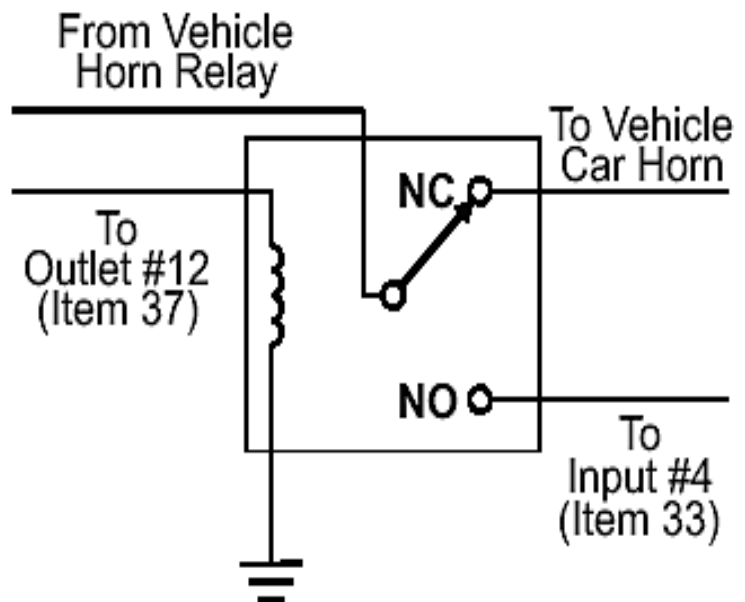
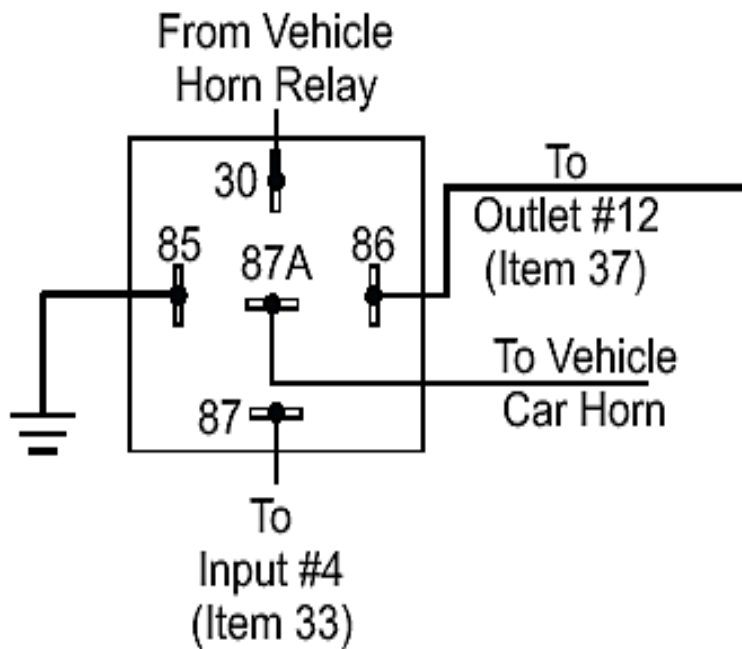

Relays

Relay Wiring Guide and Terminal Numbers

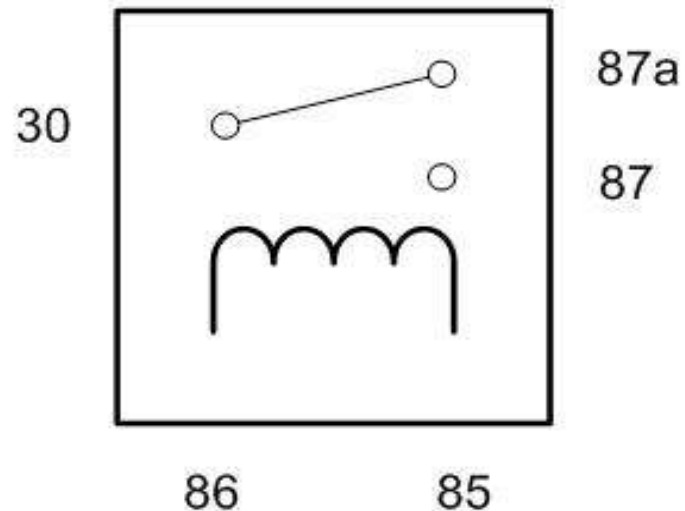

30 - High Power Feed (Must be Fused!)

85 - Relay Coil Ground

86 - Relay Coil Feed (Trigger Wire)

87 - High Power Output - Normally Open Contact

87a - High Power Output - Normally Closed Contact

Diagnostic Equipment / Tools

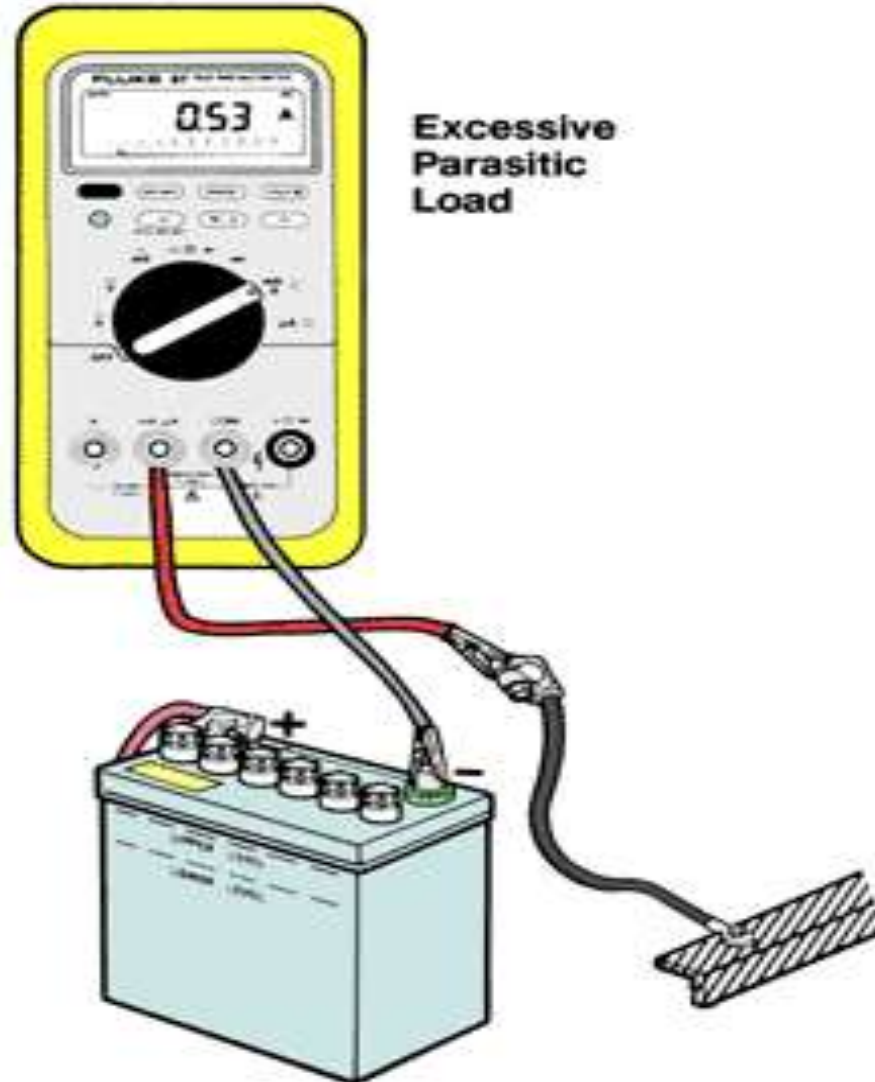

Diagnostic Equipment / Tools

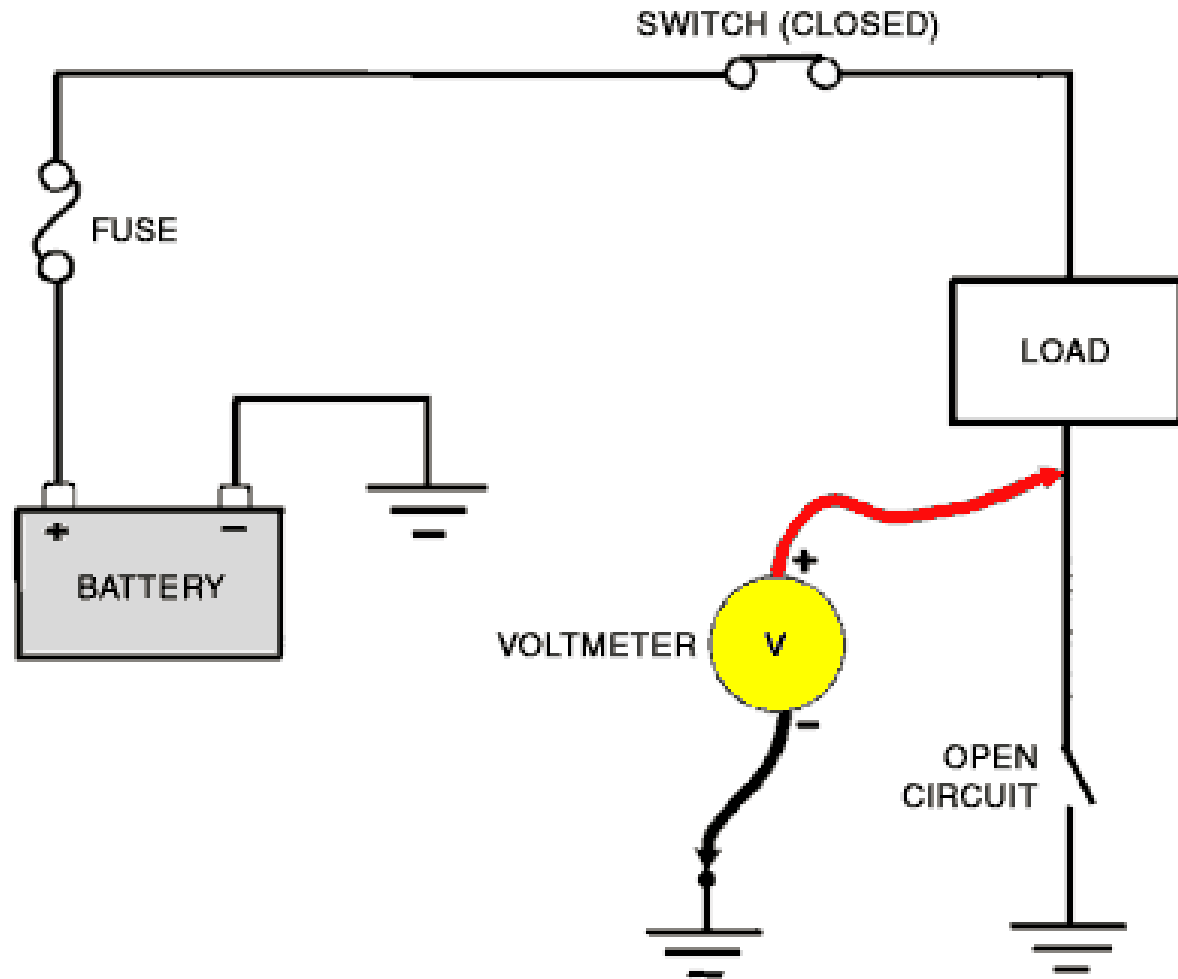

Diagnostic Equipment / Tools

- Use a regulated power supply to test products
- Most digital multimeters sold today for testing industrial, electrical, and electronic systems have high impedance input circuits greater than 1 megohm. In simple terms this means that when the DMM is placed across a circuit for a measurement, it will have little impact on circuit performance.



Diagnostic Equipment / Tools

Soldering/ Welding

- Use rosin core solder
- Acid core is corrosive to circuits
- Use a torch for larger cables, such as battery terminals
- Disconnect battery before welding anything on a vehicle
- Boran steel cross member should never be welded on



Circuit Protection

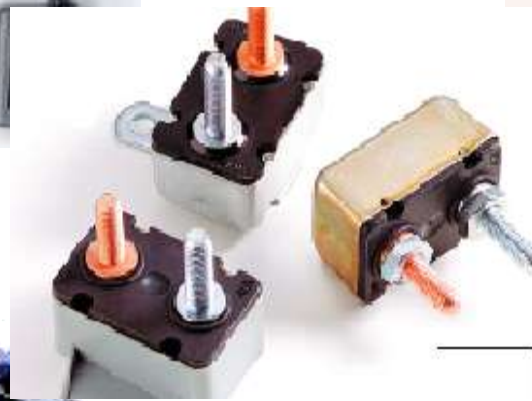
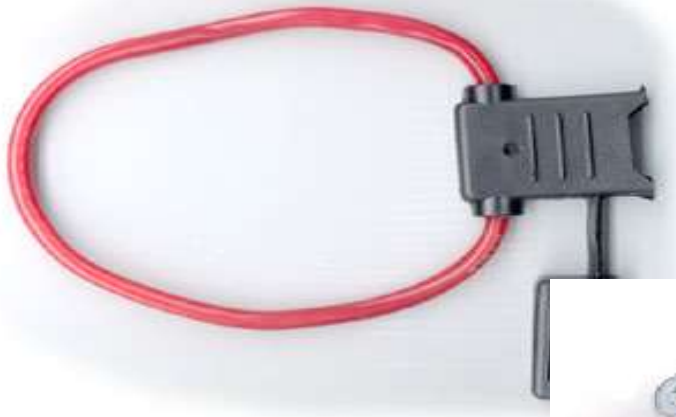

Circuit Protection

- Fuse or Circuit Breaker ?
- Follow the manufacturer's suggestion
- How Far Away From Power Source ?
- No more than 18 inches from the power source
- How Large a Fuse ?
- Fuse or circuit breaker should be rated to carry at least 125% of the load (industry standard)
- Ford recommends 135%
- What Type of Fuse ?



Circuit Protection

- (2) 12 awg wires in parallel, can carry more current than (1) 10 awg wire
- The male part of the quick disconnect connector should be attached to the load side, to avoid shorting the power wire to ground



SHORT STOP
12V HI 518







CAUTION
DO NOT TOUCH THE BATTERY TERMINALS OR THE BATTERY CASE WHILE THE ENGINE IS RUNNING.
IF YOU DO, YOU MAY BE SHOCKED OR BURNED.
DO NOT TOUCH THE BATTERY TERMINALS OR THE BATTERY CASE WHILE THE ENGINE IS RUNNING.
IF YOU DO, YOU MAY BE SHOCKED OR BURNED.

WASHER FLUID ONLY

WASHER FLUID



ONLY



INSTALLATION AND TROUBLESHOOTING



SAE Class 1,2,3

- Class 1 (brightest) , Class 1 “Clearing Traffic” = 18,000 cd-s/m
- Class 2, Class 2 “Blocking Traffic” = 4,500 cd-s/m (25% of Class 1)
- Class 3 (dimmiest). Class 3 “Identification only” = 1,800 cd-s/m (10% of Class 1)
- While SAE labels Class 2 as the standard for blocking traffic (your vehicle is stopped and blocking a lane), keep in mind that SAE is a minimum standard. We always recommend Class 1 unless special circumstances exist such as the vehicle is in a warehouse or a dark mine, etc. and Class 1 might be too obnoxious. For roadway applications, though, Class 1 is the class to go with if you want the brightest light.



Lightbars

- Modern police vehicle packages come with power and ground hook-ups somewhere in the vehicle
- LED



Safety First

This document provides all the necessary information to allow your product to be properly and safely installed.

Before beginning the installation and/or operation of your new product, the installation technician and operator must read this manual completely.

Important information is contained herein that could prevent serious injury or damage. Proper installation of this product requires the installer to have a good understanding of automotive electronics, systems and procedures.



If this manual states that this product may be mounted with tape or Velcro™, clean the mounting surface with a 50/50 mix of isopropyl alcohol and water and dry thoroughly.

Do not install this product or route any wires in the deployment area of your air bag. Equipment mounted or located in the air bag deployment area will damage or reduce the effectiveness of the air bag, or become a projectile that could cause serious personal injury or death.

Refer to your vehicle owners manual for the air bag deployment area. The User/Installer assumes full responsibility to determine proper mounting location, based on providing ultimate safety to all passengers inside the vehicle.



For this product to operate at optimum efficiency, a good electrical connection to chassis ground must be made. The recommended procedure requires the product ground wire to be connected directly to the NEGATIVE (-) battery post.

This product contains either strobe light(s), halogen light(s), high-intensity LEDs or a combination of these lights. Do not stare directly into these lights. Momentary blindness and/or eye damage could result.

FAILURE TO FOLLOW THESE SAFETY PRECAUTIONS AND INSTRUCTIONS COULD RESULT IN DAMAGE TO THE PRODUCT OR VEHICLE AND/OR SERIOUS INJURY TO YOU AND YOUR PASSENGERS!



Routing your Lightbar Cable(s)

1. To protect the headliner from damage caused by drilling the cable access hole through the vehicle roof, allow a 5" to 7" distance between roof and headliner by lowering the headliner before drilling.
2. Using a 1" hole saw, drill the cable access hole.

NOTE: There may be a roof support member that spans the distance between the driver's and passenger's side. DO NOT DRILL THROUGH THIS MEMBER! Adjust the location until the hole can be drilled without contacting this support member.

Drill cable access hole in appropriate area for your lightbar



3. Use a round file to smooth and de-burr the edges of the hole.
4. Insert a 1" grommet (user supplied) into the cable access hole.
5. Insert the cable(s) through the cable access hole into the vehicle. Use Oxygen Sensor Safe RTV silicone to weatherproof the access hole after the cable(s) are pulled completely into the vehicle.
6. Route the cable(s) down through the B-pillar. The cable(s) must make a 90° turn to enter the B-pillar. Although routing the cable in this manner may be difficult, this has been determined to be the best procedure. It is up to the installation technicians discretion whether to route the cable(s) as recommended or use an alternative route. Pull the full length of the cable(s) out of the hole at the base of the B-pillar and route towards your switch panel. Refer to the instructions included with your switches for switch wiring information.



Power Cable:

1. Open the wiring shield lid (Fig. 1) and route the power cable into the wiring shield and towards the firewall. Follow the factory wiring harness through the firewall. It may be necessary to drill a hole in the firewall. If so, be absolutely sure that there are no components that could be damaged by drilling. After the hole has been drilled, insert a grommet to protect the cable.
2. Route the cable along the factory wiring harness towards the battery. Install a 40 amp fuse block (customer supplied) on the end of the RED wire in the power cable. Remove the fuse from the fuse block before connecting any wires to the battery.
3. Connect the fuse block to the POSITIVE (+) terminal on the battery. There can not be more than two (2) feet of wire between the fuse block and the battery. The wire between the fuse block and the battery is “unprotected”, do not allow this wire to come into contact with any other wires.
4. Connect the BLACK wire to the factory chassis ground adjacent to the battery. **WARNING!** All Customer supplied wires that connect to the positive terminal of the battery, must be sized to supply at least 125% of the maximum operating current and be fused at the battery to carry the load.



Routing wires into areas exposed to wheel splash should be avoided. When such routing cannot be avoided, adequate clipping and/or protective shields are required to protect the wires from stone and ice damage.

Allow adequate slack in wiring between the engine and stationary components to compensate for engine roll.

Routing wires under the frame side members or at points lower than the bottom frame flange is not recommended. Use plastic “zip” straps for “bundling” only (securing to other wires).

The wire retainers and grommets installed by the assembly plant are usually designed to accommodate only the Ford-installed wires. Additional wiring or tubing should be retained by additional clips. When added wires or tubes are routed through sheet metal panels, new holes with proper wire protection and sealing must be used.



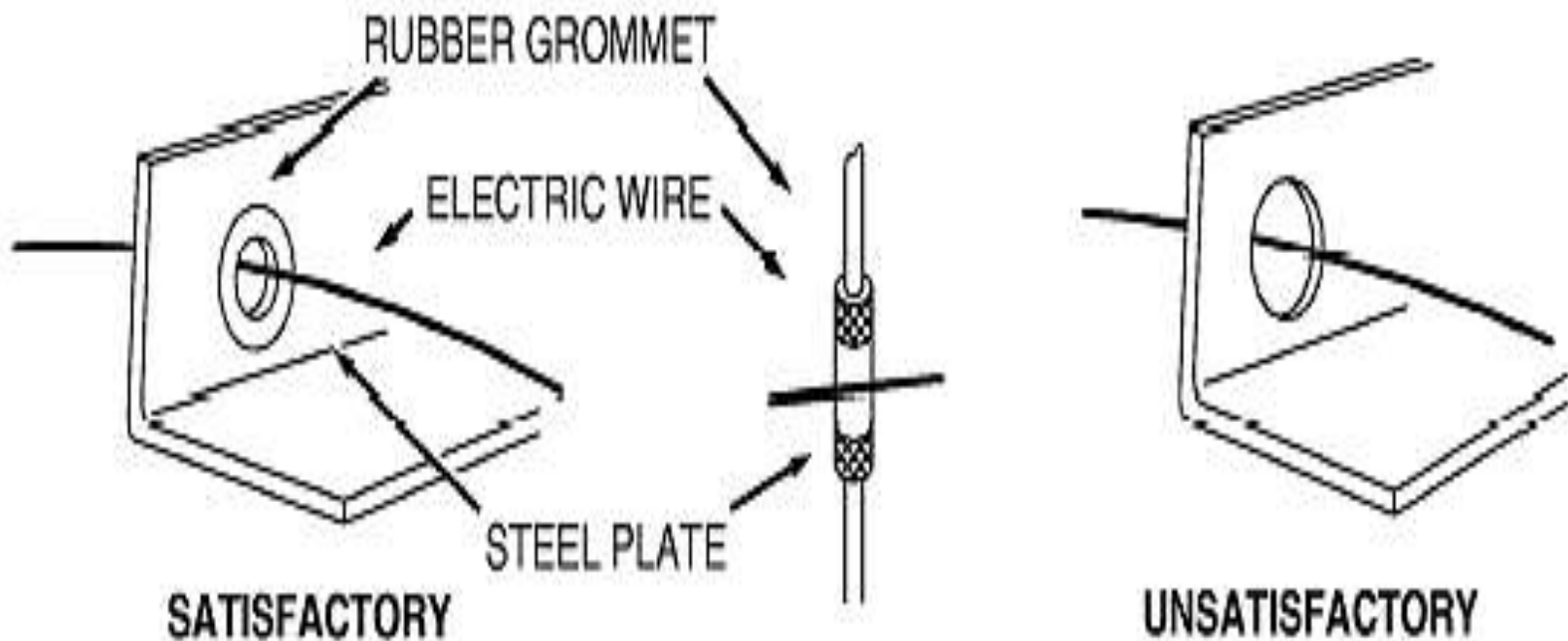

- Cables should not be in contact with sharp edges or pierced holes.

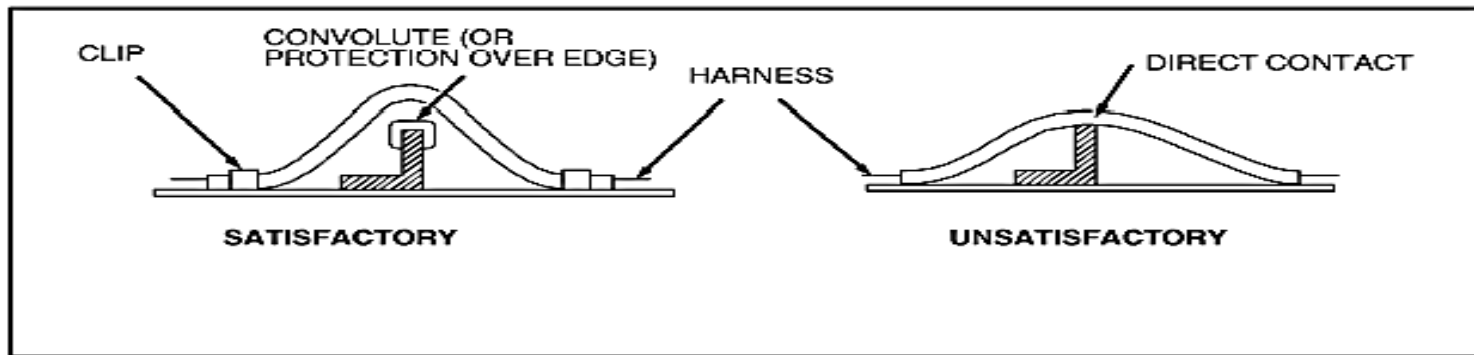

A0073514

- Wires must be routed to provide at least three inches of clearance to moving parts in their extreme movement location, unless positively fastened and protected by a conduit.
- Wire routing without conduit should be avoided in areas where temperatures exceed 82°C (180°F). Minimum clearance of six inches should be maintained from exhaust system components. Heat insulation and heat shields must be used on the wires routed in high temperature areas.
- Make certain that all underhood or underbody wiring is cross-linked polyethylene high temperature insulation wire 135°C (275°F) (minimum rating) consistent with SAE specification J1128 Type SXL wire. Normal PVC wire must not be used in underhood or underbody applications.
- Make sure all ground locations are readily accessible for installation, service and verification.
- Do not place ground attachments in high-splash areas.
- Do not route underbody wiring over the exhaust system.
- Underhood/underbody wiring must be routed in conduit for protection. Minimum conduit rating is 177°C (350°F).

Wire Retention and Routing

Use the following criteria to determine the location of retainers:

- Size and weight of wire bundle.
- Holes with poor accessibility that prevent installation of locators.
- Movement of wires that can result in abrasion, squeaks and rattles.
- When wiring is routed between two members where relative motion can occur, the wiring should be secured to each member with enough wire slack to allow flexing without damaging the wire.
- Wiring exposed to weather must provide a drip loop to prevent moisture from being conducted into the device through the wire connection (see figure below).

Troubleshooting Lightbar

Your lightbar should now be fully operational. If your lightbar is not functioning properly, check the following:

- **The positive wire (RED) is properly connected to the battery, by way of the user supplied fuse block.**
- **A working fuse of the correct amperage (40 amp) is installed in the fuse block.**
- **The ground wire (BLACK) is properly connected to the factory ground.**

If all of these connections are good, contact your Whelen representative for further assistance.



Troubleshooting LED Lightbars

- LED Module
- LED Flasher
- LED I / O Board
- LED Ballast / Power Supply
- Wiring Gremlins
- Defective Wiring Connectors



Dash Mounted Lights



- Heat from defroster can degrade LED
- Flash back from the light may interfere with driver vision
- Be sure that dash lights are installed away from the deployment zone of the air bag



Sirens And Speakers

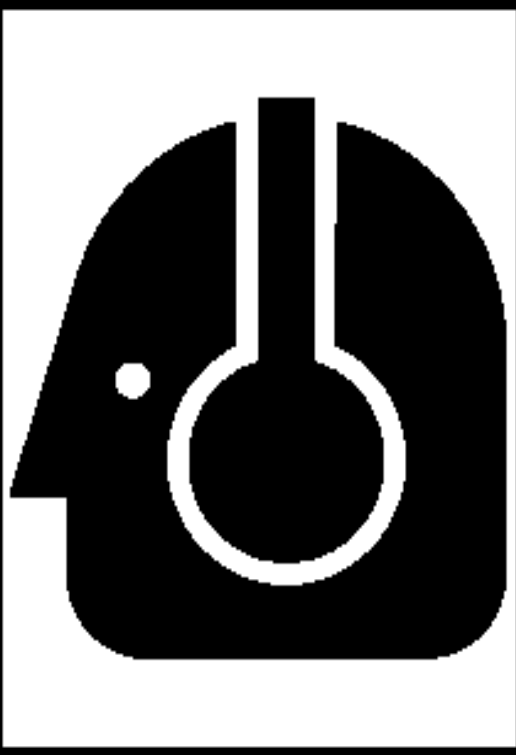

Sirens And Speakers

	 CAUTION
	<p>Loud siren noise Can cause Hearing loss</p> <p>Minimize exposure Close windows when using</p>

Sirens And Speakers

⚠ WARNING

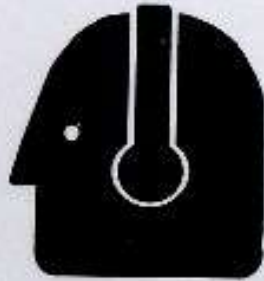

Sirens produce loud sounds that may damage hearing

- Roll up windows
- Wear hearing protection
- Use only for emergency response
- Avoid exposure to siren sound outside of vehicle

Refer to instructions or call 1-800-433-9132



Sirens And Speakers

- Route the RED and BLACK wires along the factory harness towards the battery.
- Remove the fuse from the fuse block before connecting any wires to the battery!
- There must not be more than 18 inches of wire between the fuse block and the battery. As the wire between the fuse and the battery is “unprotected”



Sirens And Speakers

Decibels	
pain threshold	140 dB
jet take-off	
Class A siren	120 dB
rock group	100 dB
jackhammer	
street traffic	80 dB
normal speech	60 dB
business office	
library	40 dB
forest	20 dB
hearing threshold	0 dB

fig. 2

Sirens And Speakers

- The siren should be installed in negative ground vehicles with 12-volt electrical systems. It is protected against failure modes (including reversed polarity) by a fuse that is replaceable without tools.
- If wiring is shorted to vehicle frame, high current conductors can cause hazardous sparks resulting in electrical fires or flying molten metal.
- Sound output will be severely reduced if any objects are in front of the speaker.



Sirens And Speakers

- Install the speaker(s) as far forward on the vehicle as possible, in a location which provides maximum signaling effectiveness and minimizes the sound reaching the vehicle's occupants.
- Sound propagation and warning effectiveness will be severely reduced if the speaker is not facing forward.
- Listen for tone generator, sign of bad speaker



Sirens And Speakers

- DO NOT install the speaker(s) or route the speaker wires where they may interfere with the operation of air bag sensors.



Sound Wave Interference

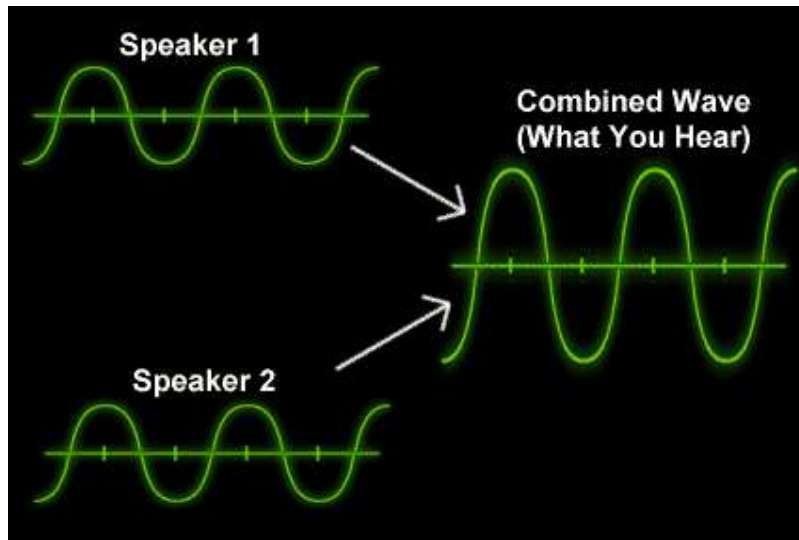

Constructive Interference

Destructive Interference

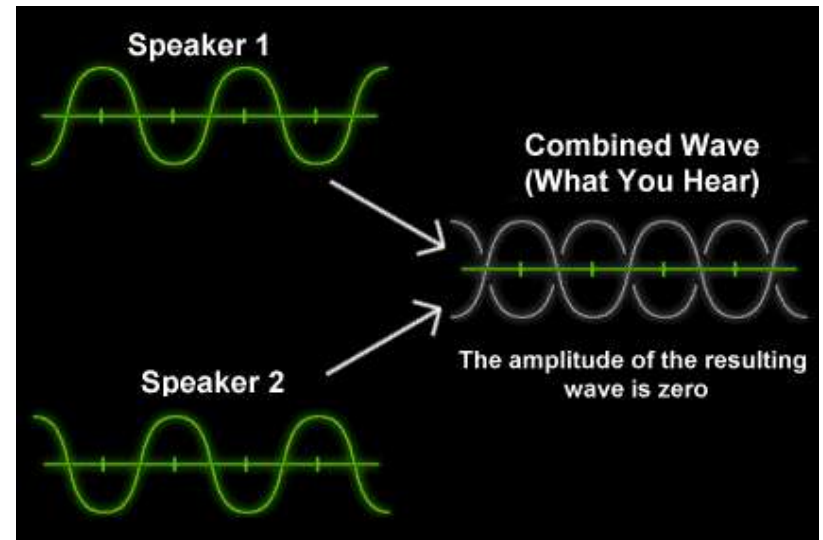

Wig-Wag Headlights



Installation

There are two different switching methods used to activate the headlights/parking lights in a motor vehicle; **Positive-Side** Switching and **Ground-Side** Switching. For example, the headlights may use Positive-Side switching, while the parking lights may use Ground-Side switching. Before installing this product, it will be necessary to contact the vehicle manufacturer to determine which methods are used. After the proper methods have been established, follow the appropriate procedure, based on the method used by the headlight system.



Positive-side Switched Headlights

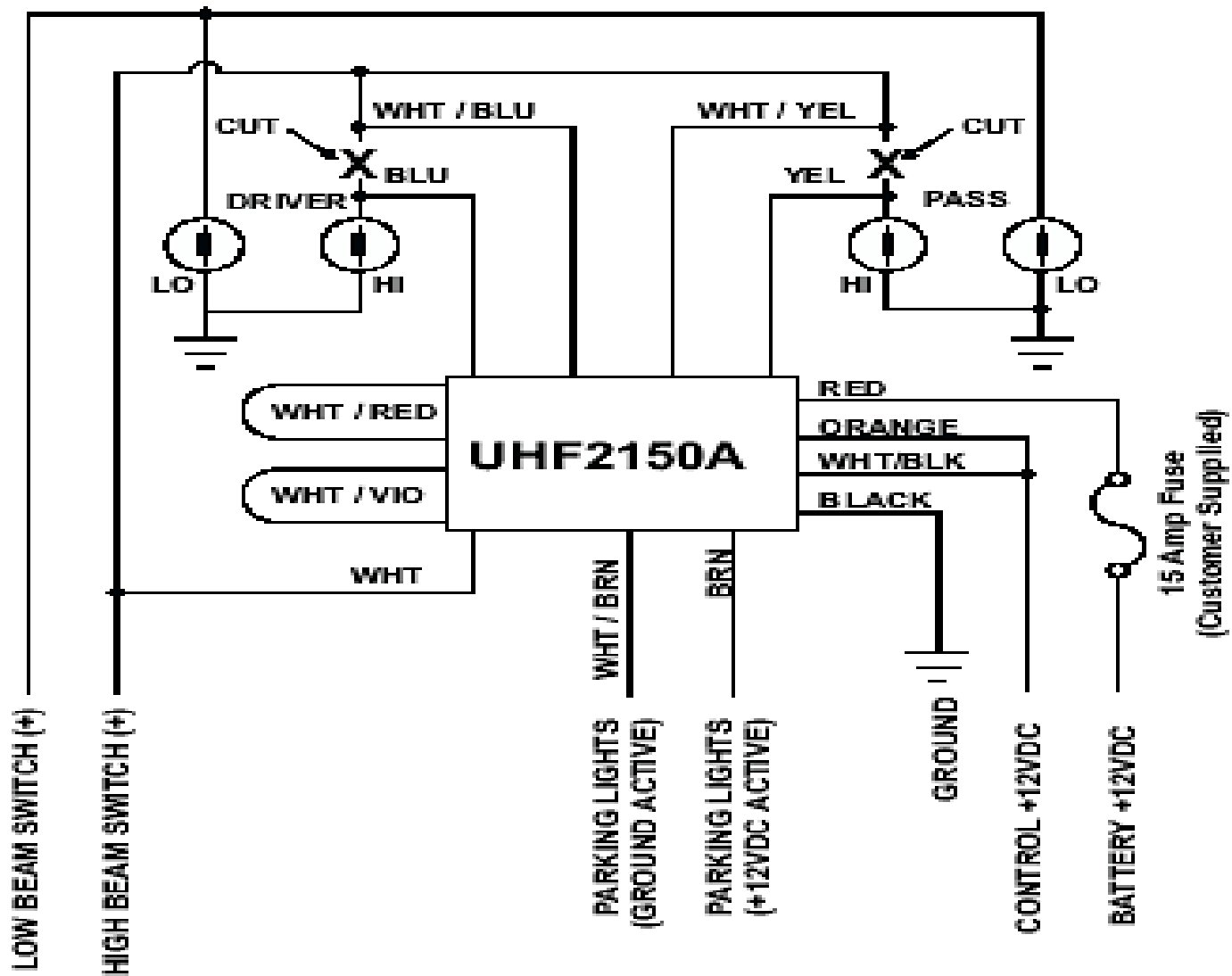

Trouble Shooting Wig-Wags

- Newly installed wig-wags, the headlights flash as they should. When the high beam switch is activated only one headlight comes on. What is the cause?
- After installing a wig-wag flasher only one headlight will flash. What are possible causes of this problem?
- A wig-wag flasher will not work at all.
WHY?



Strobe Systems



WARNING!The Strobe Light Power Supply is a high voltage device. Do not touch or remove tube assembly in strobe light head assemblies while in operation. Wait 10 minutes after disconnecting the unit from its power source before starting work or troubleshooting on power supply or system.



L.E.D.

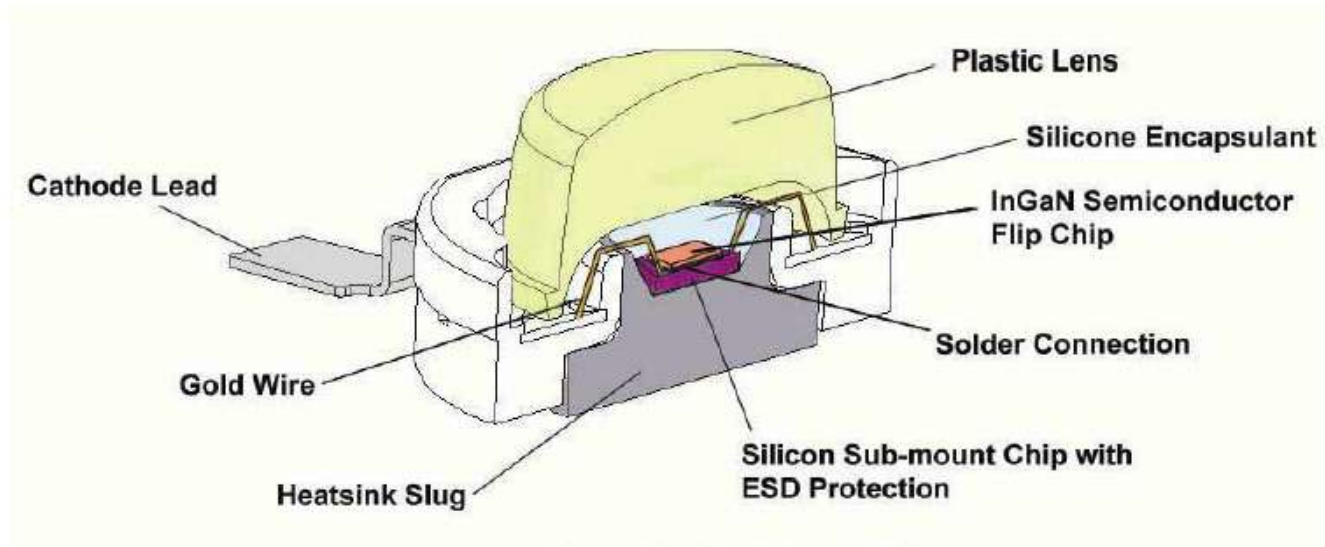

Red	$610 < \lambda < 760$	$1.63 < \Delta V < 2.03$	Aluminium gallium arsenide (AlGaAs) Gallium arsenide phosphide (GaAsP) Aluminium gallium indium phosphide (AlGaInP) Gallium(III) phosphide (GaP)
Blue	$450 < \lambda < 500$	$2.48 < \Delta V < 3.7$	Zinc selenide (ZnSe) Indium gallium nitride (InGaN) Silicon carbide (SiC) as substrate Silicon (Si) as substrate — (under development)
White	Broad spectrum	$\Delta V = 3.5$	Blue/UV diode with yellow phosphor



L.E.D.

- LEDs
 - About LEDs
 - “Light Emitting Diode”



Gen 1 or “T 1-3/4”



Gen 2 or “*Super Flux*”

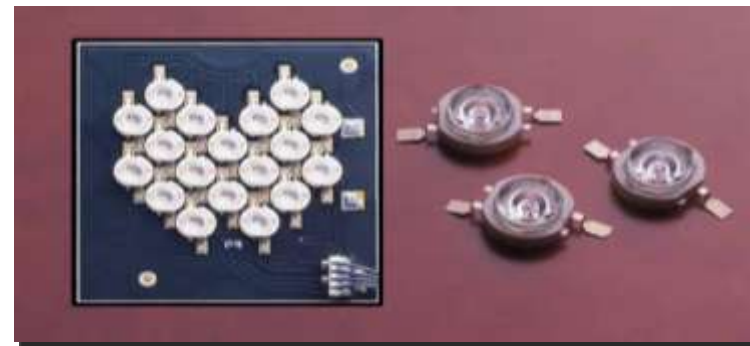

Gen 3 or “*High Flux*”

L.E.D.



- WHY LEDs?
- Low Amp Draw
- Long Life
- Withstand Vibration
- Typically built-in flasher, but can be synchronized
- Low current draw – less than 1 amp per module
- Typically, no serviceable parts.
- Clear or Colored lenses
- LED Modules are Not Field Serviceable



L.E.D.

- Two identical LEDs flash at a different rate.
 - Consider whether built-in flashers are on the same pattern.
 - Consider if pattern “phasing” is occurring.
- Can I use a Strobe Power Supply to flash LEDs?
 - NO, unless there is a specific LED flashing circuit combined with the Strobe Power Supply.
 - DO NOT TIE AN LED TO A STROBE OUTLET!



Lighthouse is filled with moisture.

- All Lighthouses are designed to “breathe” and condensation is an expected occurrence.
- Assure drain holes are in the correct orientation.
- Reposition wire to eliminate a drip path.
- An old strobe fixture is replaced with an LED upgrade. Can the old wire be used?
- The wire itself, yes. But not by using the Strobe Supply.
- LED lighthouses are polarity sensitive red to +12 Black to ground



Traffic Pre-emption



Traffic Pre-emption

The 3M™ Opticom™ Priority Control System consists

of the following matched components:

- **Emitter**
- **Optical Detector**
- **Phase Selector**
- **Interface Card**
- **System Chassis**



Traffic Pre-emption

The Model 4592 emitter power supply converts 12 Volt DC vehicle battery voltage to the high voltage required for the emitter to operate. The installation wiring and internal switch settings determine the unit's mode of operation. The unit may be installed as a Low-priority emitter or as a High-priority emitter by simple variations in the installation wiring.

An appropriate vehicle class and ID number is determined at the time of installation and is programmed by setting internal code switches.



Traffic Pre-emption

- Do not mount the emitter within 18 inches of a radio antenna.
- The emitter should point straight ahead, and should be mounted level and as high on the vehicle as possible.
- The emitter must not be obstructed by other lights, speakers, grill work, antennas, or other devices.
- The emitter should not be mounted inside the
- passenger compartment.



Traffic Pre-emption

- Disconnect the battery before beginning the installation. Disconnect the negative battery cable first, then the positive battery cable.
- Emitter installations may include a disable switch in addition to the accessory switch. The Latching Disable feature turns off the emitter when the disable switch closes to battery negative. This feature typically uses an existing switch that indicates the presence of conditions deemed appropriate to disable the emitter. Such conditions include putting the transmission in park, setting the parking brake, or opening the vehicle operator's door.



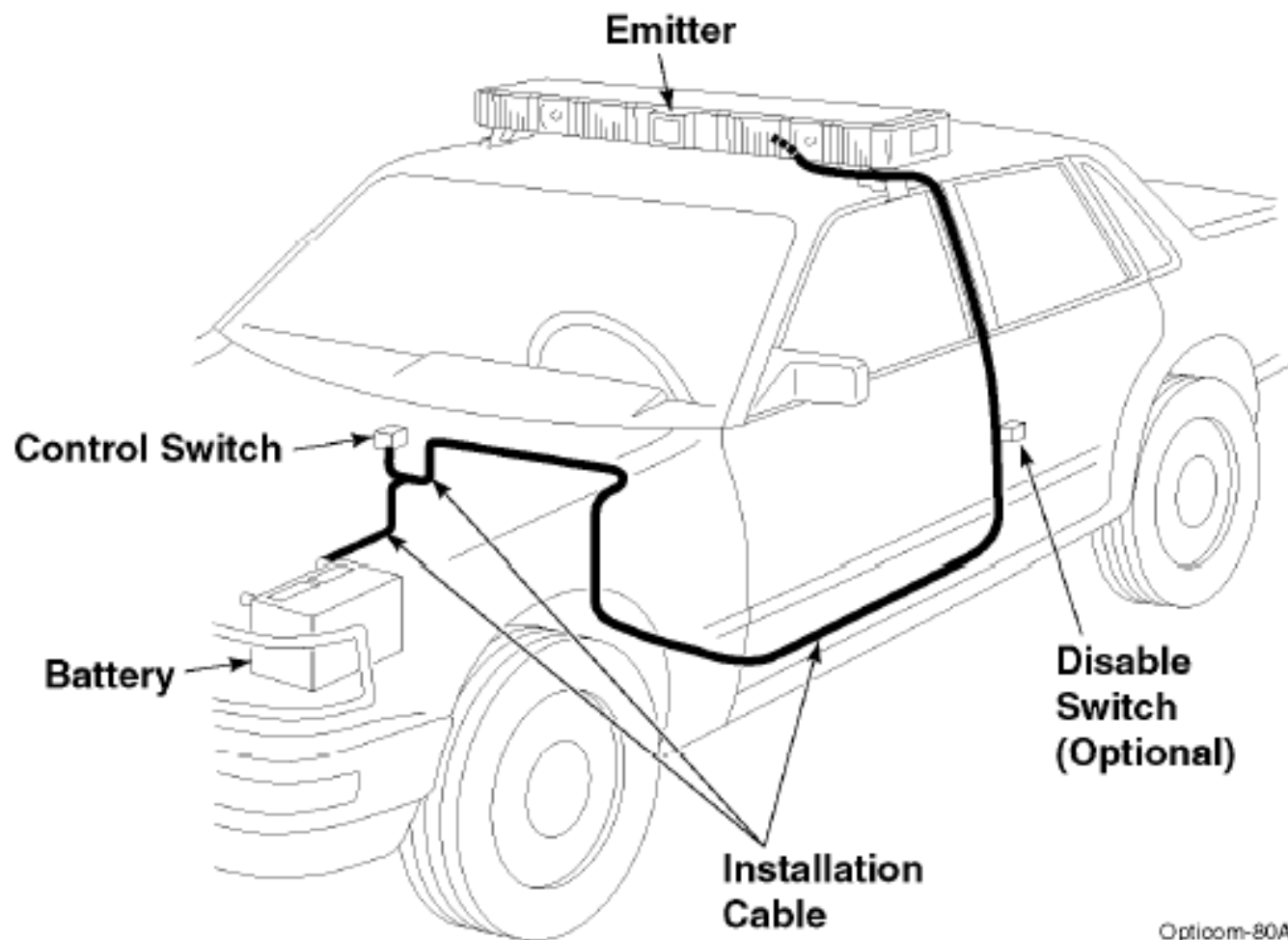

Opticom-80A



Radios



Radios

- First Install of some radios must be done by factory authorized installers
- Always run separate power and ground
- Always ground at battery or other approved ground
- Do not run radio wiring with strobe or other emergency lighting cables
- May be switched by ignition source if available from radio manufacturer
- If a radio won't transmit, check for a bad mic first



Radios

- Check Fuses First
- Check All Connections
- Replace Radio



Antennas



Antennas



Antennas

- Mount Antenna At least 16 inches away from everything
- Insure a good ground plane for the antenna
- Do NOT run antenna wire with other electronic devices
- Assure care is taken when drilling holes
- Be sure to remove all metal shavings from vehicle surface
- Do not over bend and never at 90 degree





RF Interference

- Effects of Radio Frequency Interference
- Effects of Electromechanical Interference
- RFI and EMI equal noise
- Possible cause, bad or loose grounds, defective product, improper antenna
- Ways to find, use portable radio, use oscilloscope
- Test all equipment simultaneously



RF Interference

- Lights & Sirens
- Switches
- Radios
- Cameras
- Radar
- Modems
- Cell Phones
- GPS
- Lo/Jack
- Computers



Computers

- Install computer out of air bag
- Install computer transformer to direct battery power or delay shut down timer
- If using an 120vac inverter, connect inverter directly to battery
- Mount in an approved and secure location, laptop computer specific stand or floor mount
- Laptop is the highest parasitic amp draw aftermarket device in a vehicle



Video Camera and Recorder



Video Camera and Recorder

- Place the unit in the desired location of the trunk. Make sure that the unit can be unlocked and opened easily, and tapes can be loaded and ejected conveniently.
- If you are using a windshield mounted camera, mount the foot to the window by following the directions on the included adhesive package, making sure to follow the instructions exactly.
- Remove fuse from power cable before connecting to power source



Video Camera and Recorder



Mounting of the mounting brackets
with base plate of vault attached

Video Camera and Recorder

- **No Power To Unit:** Check connections, cigarette plug fuse, and power source.
- **No Audio:** Check unit volume control settings.
- **Display Dim or Not Visible:** Check unit brightness settings.
 - **System Starts Recording On It's Own** Check the orientation of interface cable connector. Make sure the key in the connector lines up with the slot in the control head connector.
 - Verify that the green interface wire is connected to chassis ground.



RADAR



RADAR

- Follow basic wiring procedures
- Make radar units easily removable for recertification
- Assure that radar antennas are level and unobstructed
- Be sure no part of the radar unit is installed in the air bag deployment zone
- Plug the power cord into the radar unit first



RADAR

- **RFI Indicator:** Front antenna may be pointed downward and picking up air conditioning or heating fan.
- **Front Or Rear Antenna Flashing On Unit:** Turn unit off and check antenna cable connections.



Chargers (Flashlight & Radio)



1



2



3



4



5



Chargers (Flashlight & Radio)

- The Stinger charger should never be mounted against vinyl or any other heat sensitive surface. While the charger is designed to hold the Stinger in virtually any orientation, the most secure position is with the light vertical and the head up.
- It is not recommended to mount the light completely upside down in mobile applications. Although the charger is designed to allow the Stinger to be inserted or removed with zero clearance at the ends of the light, for maximum ease of insertion and removal try to leave a minimum of 1 3/4" clearance from the face cap when the Stinger is in the charger.
- Two (2) self-tapping #8 x 2" screws are included to mount the charger to a variety of surfaces. The correct size hole for these screws in sheet metal is 1/8."



Chargers (Flashlight & Radio)

- We ordinarily recommend that the charger be connected directly to the battery, through a 1-5 amp fuse, or that it be connected to an unswitched terminal on the vehicle fuse block.
- However if the vehicle is used infrequently, the charger should be connected to an ignition key-switched terminal to avoid draining the vehicle battery.
- If this is the case, it may be preferable to use an AC charger rather than leaving the Stinger in a vehicle to ensure that the Stinger receives a full charge.



Chargers (Flashlight & Radio)

- The striped power lead is positive and the unmarked lead is negative. Since the charger body is electrically isolated from the charge circuit, positive ground installations are not a problem. The Stinger is diode protected and if connected in reverse polarity simply won't operate until connected properly.
- An ignition sensor causes the vehicular charger or enhanced vehicular charger to shutdown when the ignition is switched off.



Battery Timer (Shut Down)

- The SDT protects the automobile battery from over discharge by shutting OFF up to 30 (20)amp loads at a preset time after the engine is shut down or when the battery is discharged to a low voltage level.
- The SDT also protects radio or computer equipment from damage due to low or high input voltage as experienced with alternator failure or improper voltage jump-starts.



Battery Timer (Shut Down)

- The Shut Down Timer (SDT) is intended to shut down electrical equipment at a preset delay time after the automobile engine is turned OFF. This protects the battery and the equipment from damage due to over discharge or low input voltage.
- The SDT is connected between the +12 volt of the vehicle electrical system and the loads to be controlled. The loads may be radios and computers or other electrical loads (lights and flashers).



Battery Timer (Shut Down)

- Turn the engine OFF and the Green LED will flash at a 2 Connect the GND terminal to a good chassis ground. The SDT is powered from the +BAT input and this ground.

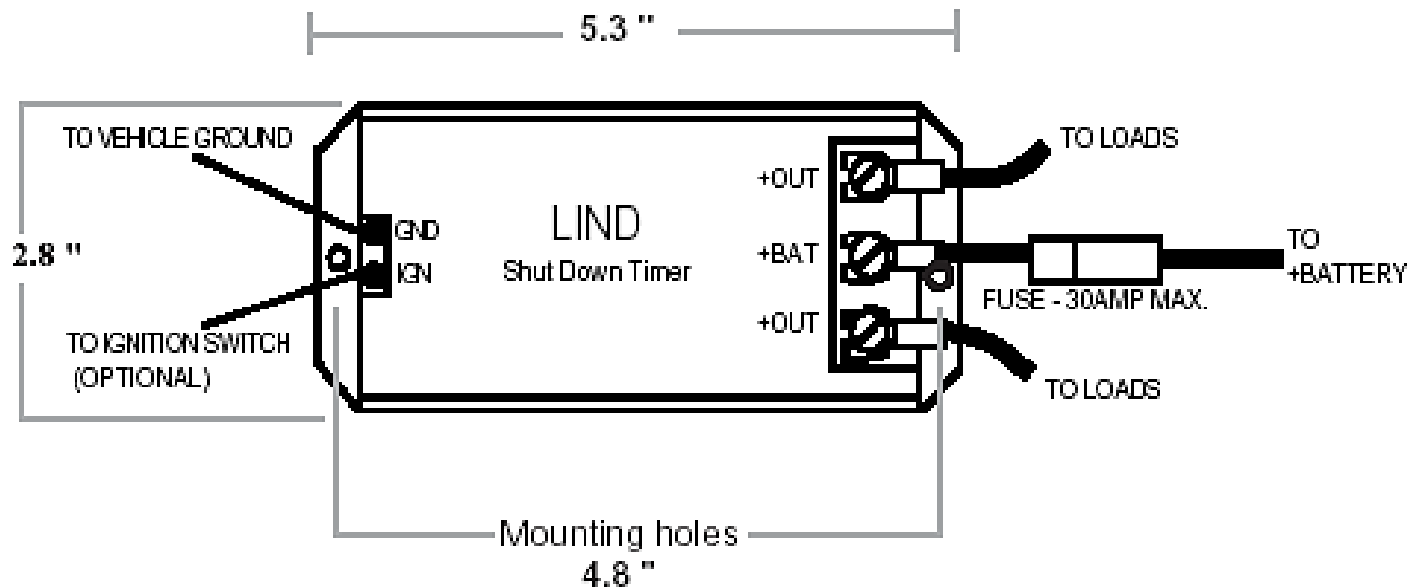

GPS / AVL

- **GPS** = Global Position System
- **AVLS** = Automatic Vehicle Location System



Air Bags / Air Bag Deployment Zones

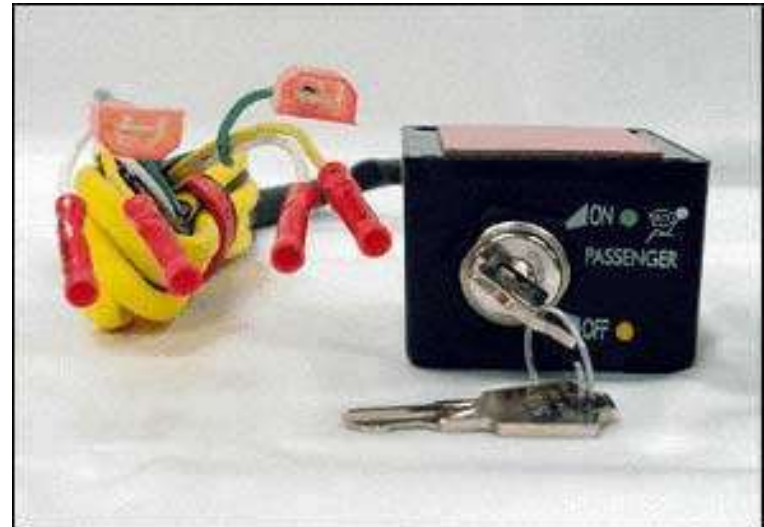

Air Bags

- **If you're going to install a system in A vehicle and are going to be probing wires of which you don't know their precise function, use a multi-meter to find the appropriate wire.**
- Don't poke/cut the wires, check wires at the connector



Airbag Warning: A test light can (read: will) set off a supplemental restraint system if the wrong wires are probed. These wires are generally (but NOT always) marked with yellow loom or tape. If you probe one of these wires (which may be in virtually ANY factory wiring harness anywhere in the vehicle), and set off a single airbag, you may easily cause THOUSANDS of dollars in damage.

If you hit the wrong sensor wire and trigger ALL of the airbags, there may be enough damage that the vehicle may be totaled from the cost to replace the bags and the affected trim panels. Some airbag systems destroy the entire dash, the door panels and even parts of the seats when they deploy.



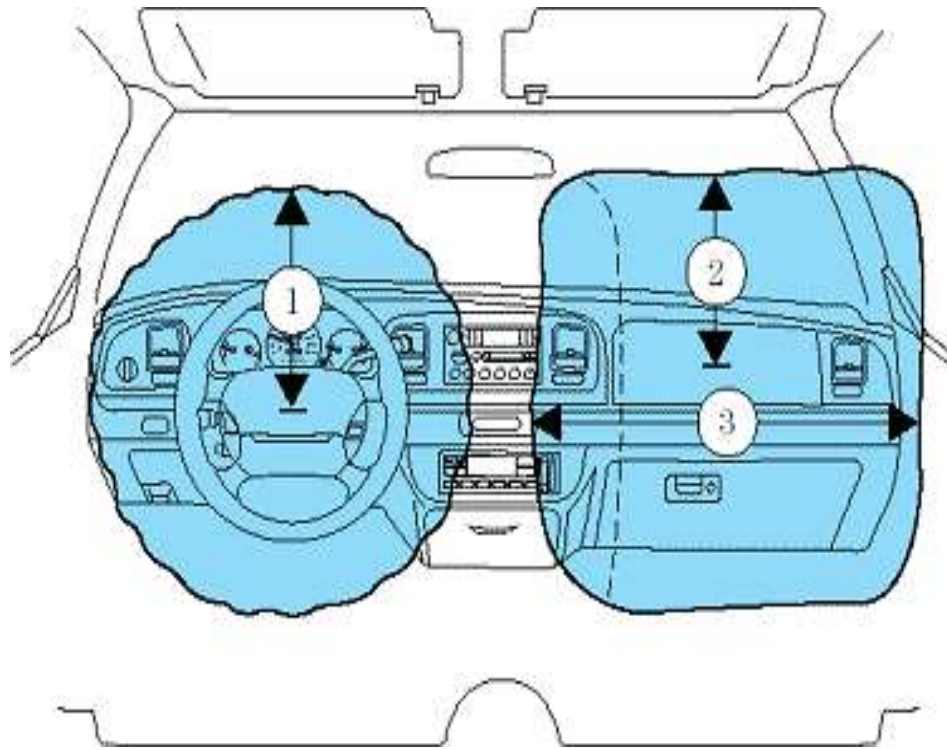

- 1) 9.5 inches from center of air bag door
- 2) 15 inches from center of air bag door
- 3) 29.5 inches

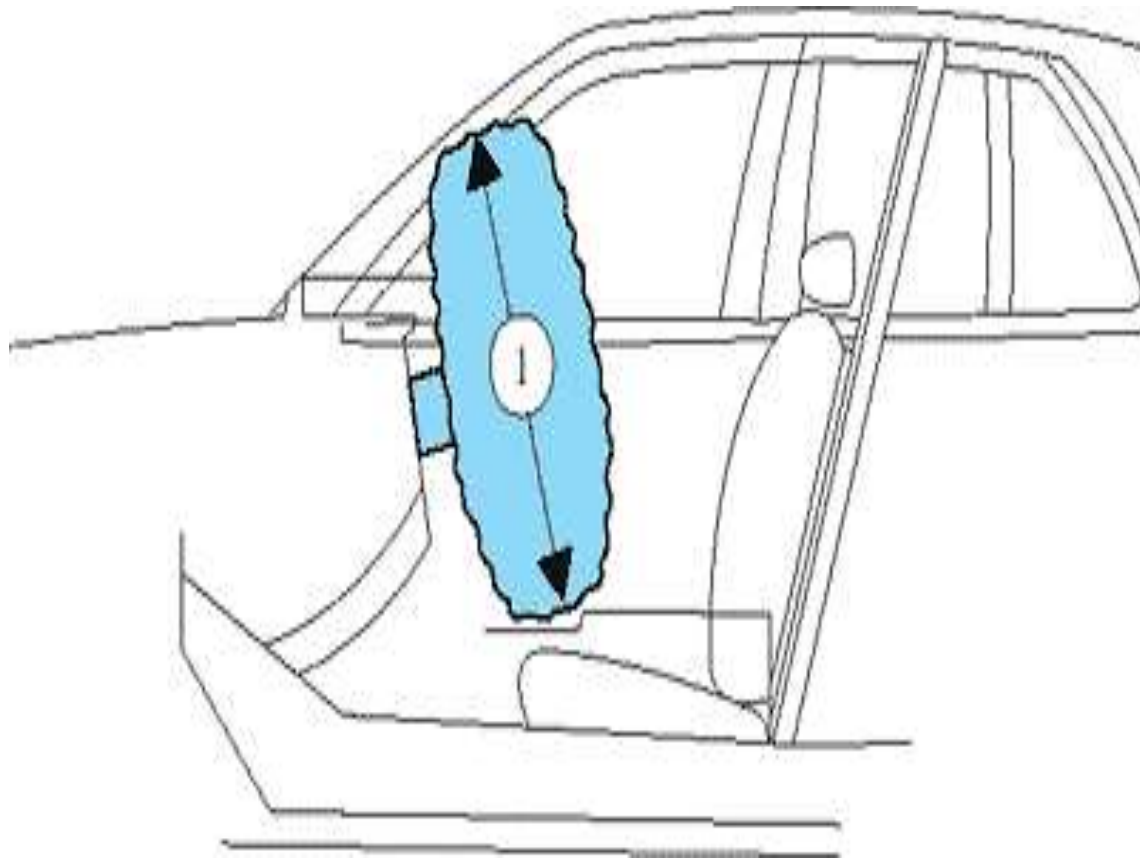

1) 26 Inches cross section of vehicle shown
(passenger side shown)



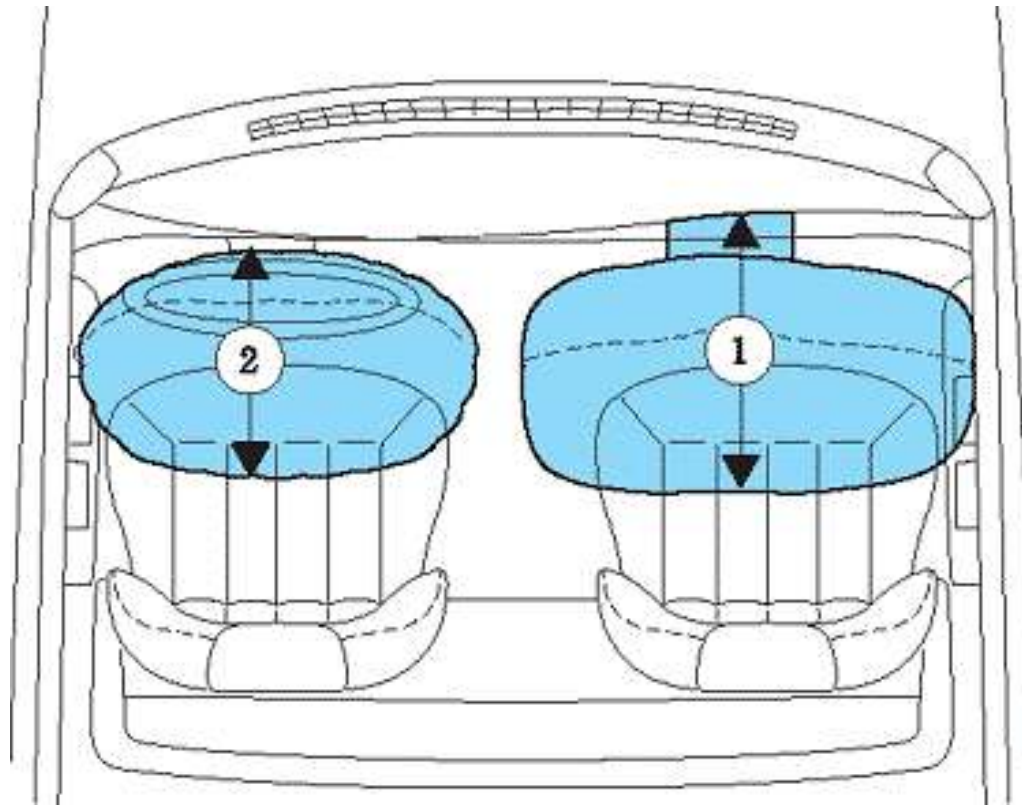

- 1) 25.5 inches front passenger compartment
- 2) 17 inches front driver



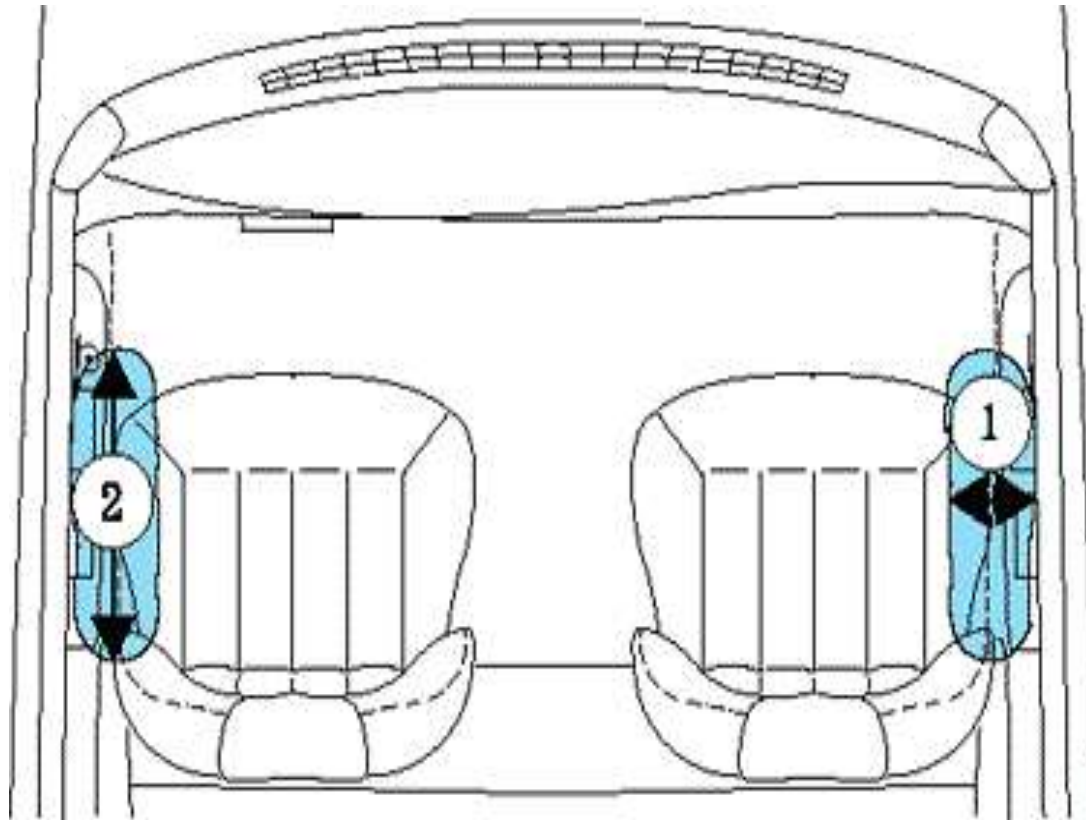

- 1) 8 inches from outboard side of seat
- 2) 15 inches forward of seat back

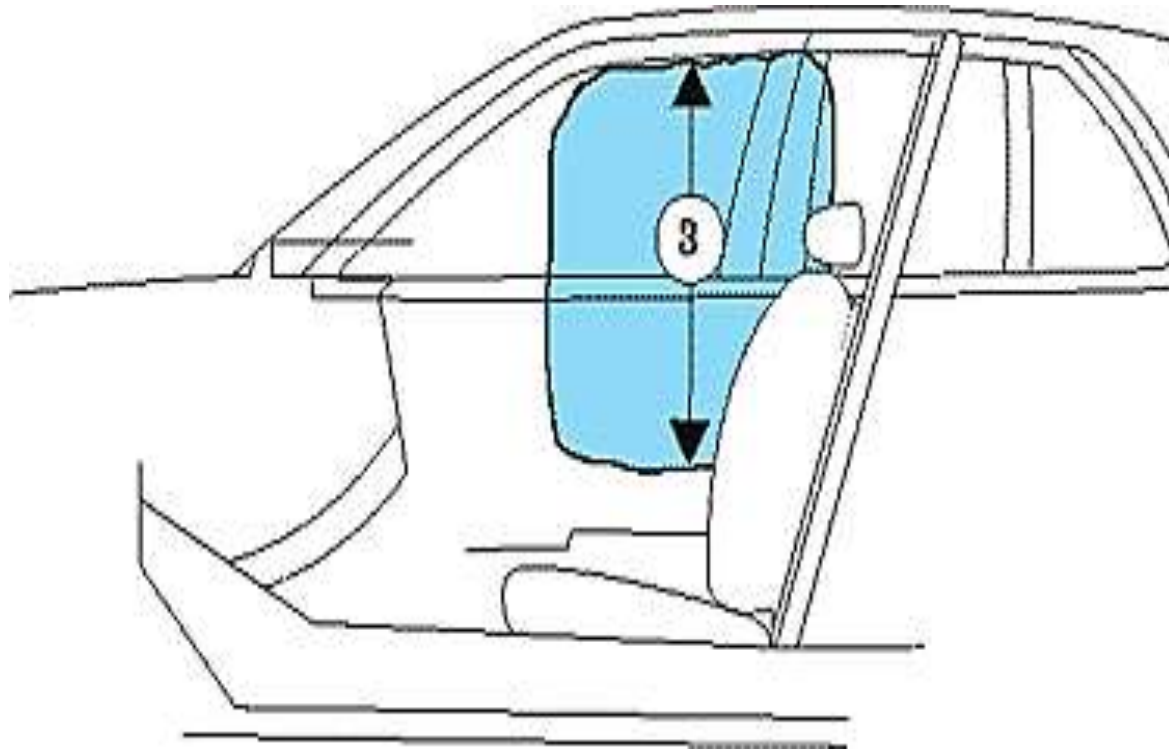

3) 27.5 inches up from SAB module



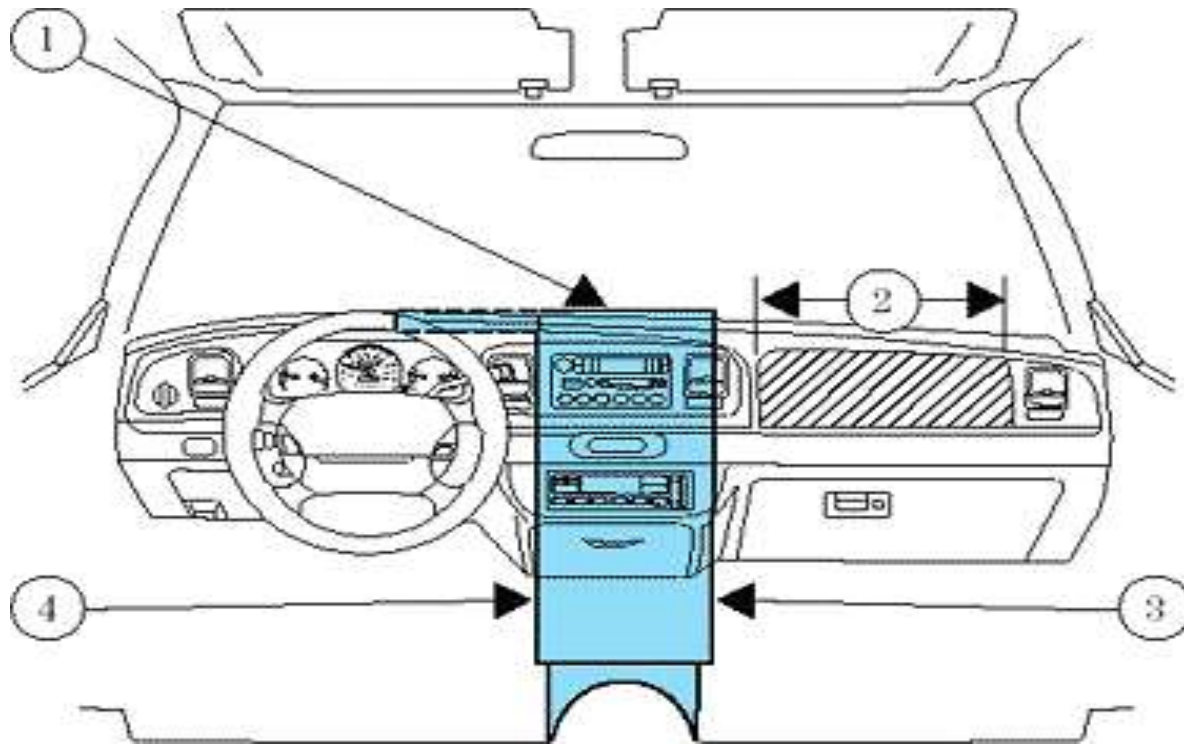

- 1) Area on top of instrument panel
- 2) Air bag door must be kept clear for deployment
- 3) Area in front of center console from bottom of Ashtray to top of instrument panel
- 4) 11 inches width



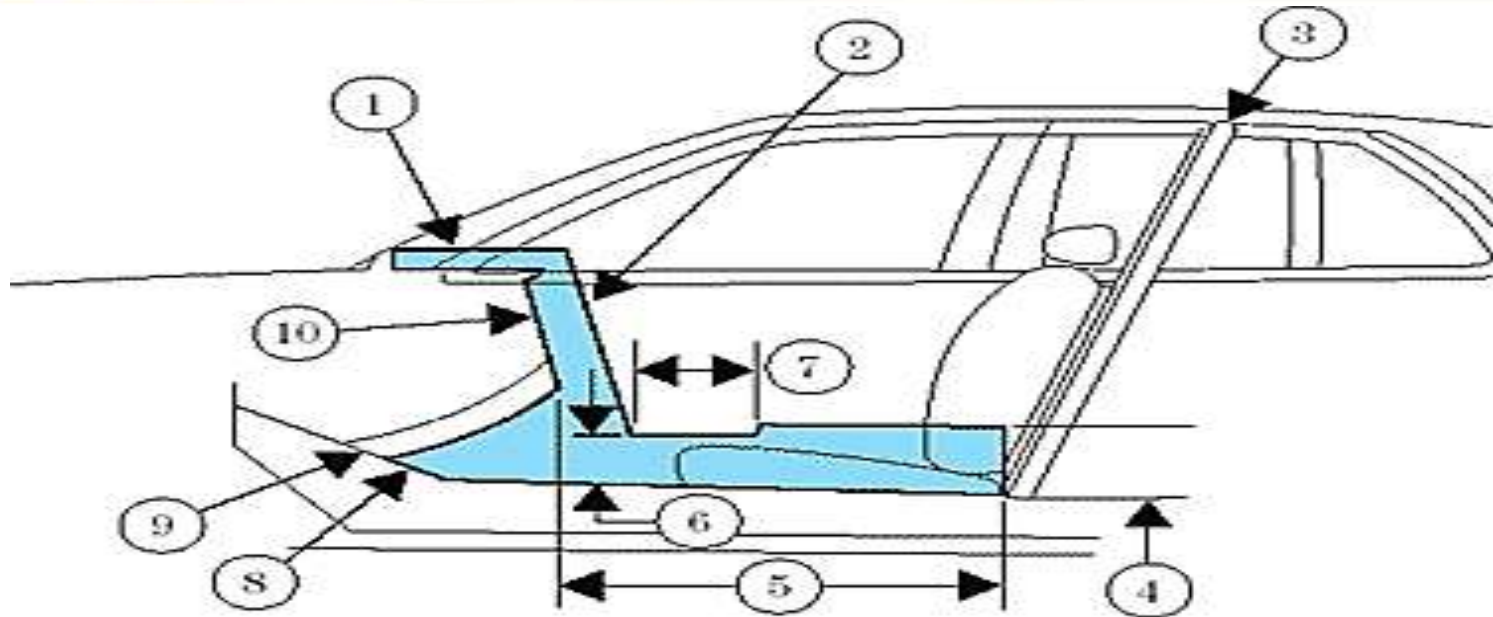

1) Area on top instrument panel

6) Height 8.5 inches

2) Area in front of center console from tunnel to instrument panel

7) 12 inches

3) Prisoner screen

8) Area on tunnel beneath center console

4) 10 inches

9) Tunnel

5) Area on tunnel between seats

10) Depth 1.5 inches



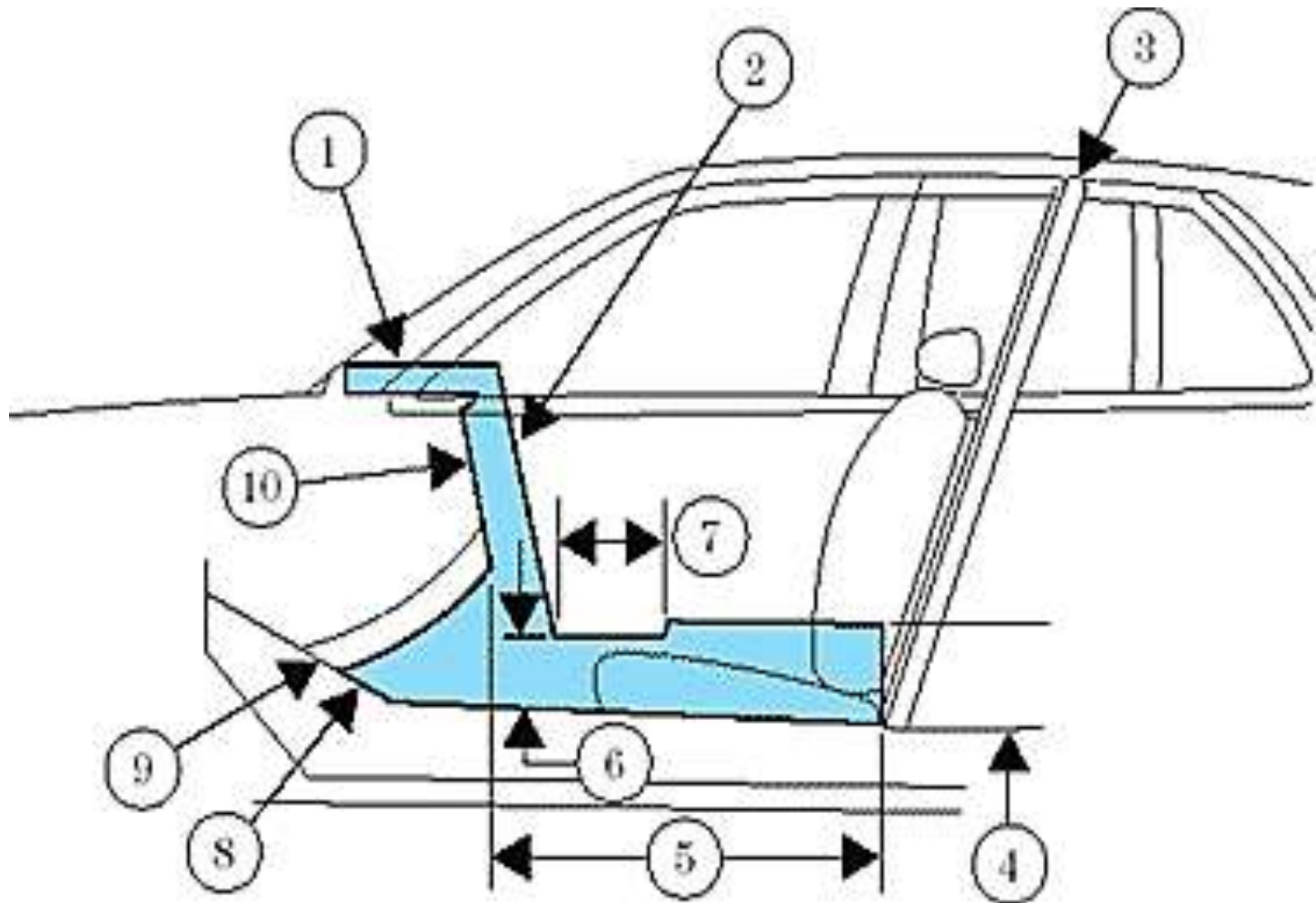

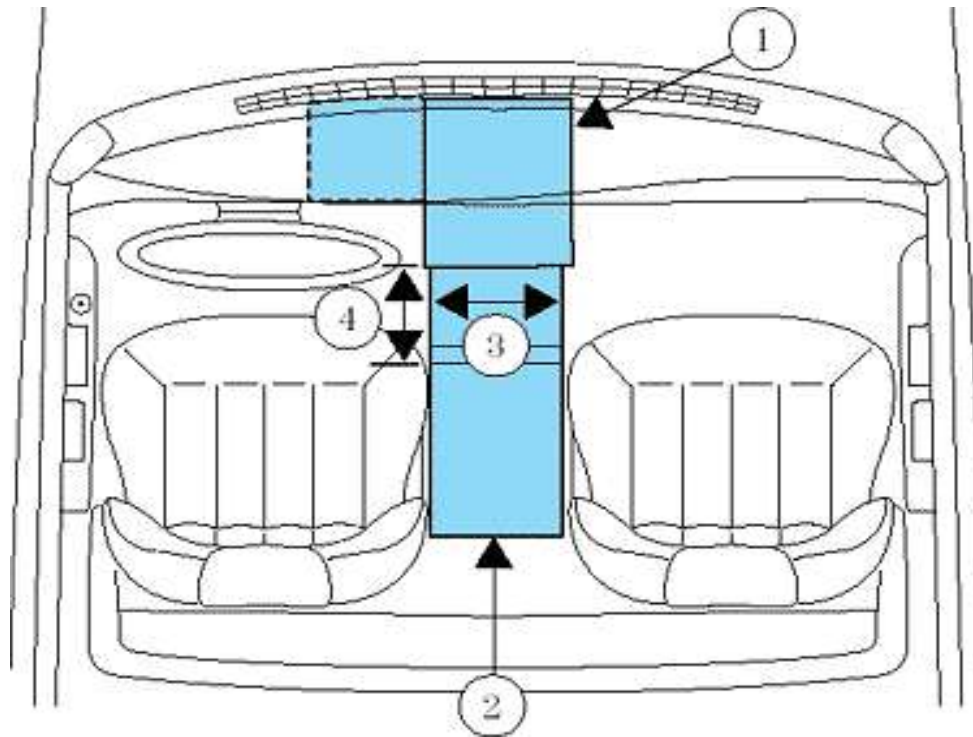

1) Area on top of instrument panel

2) Area on tunnel between seats

3) 9 inches

4) 12 inches



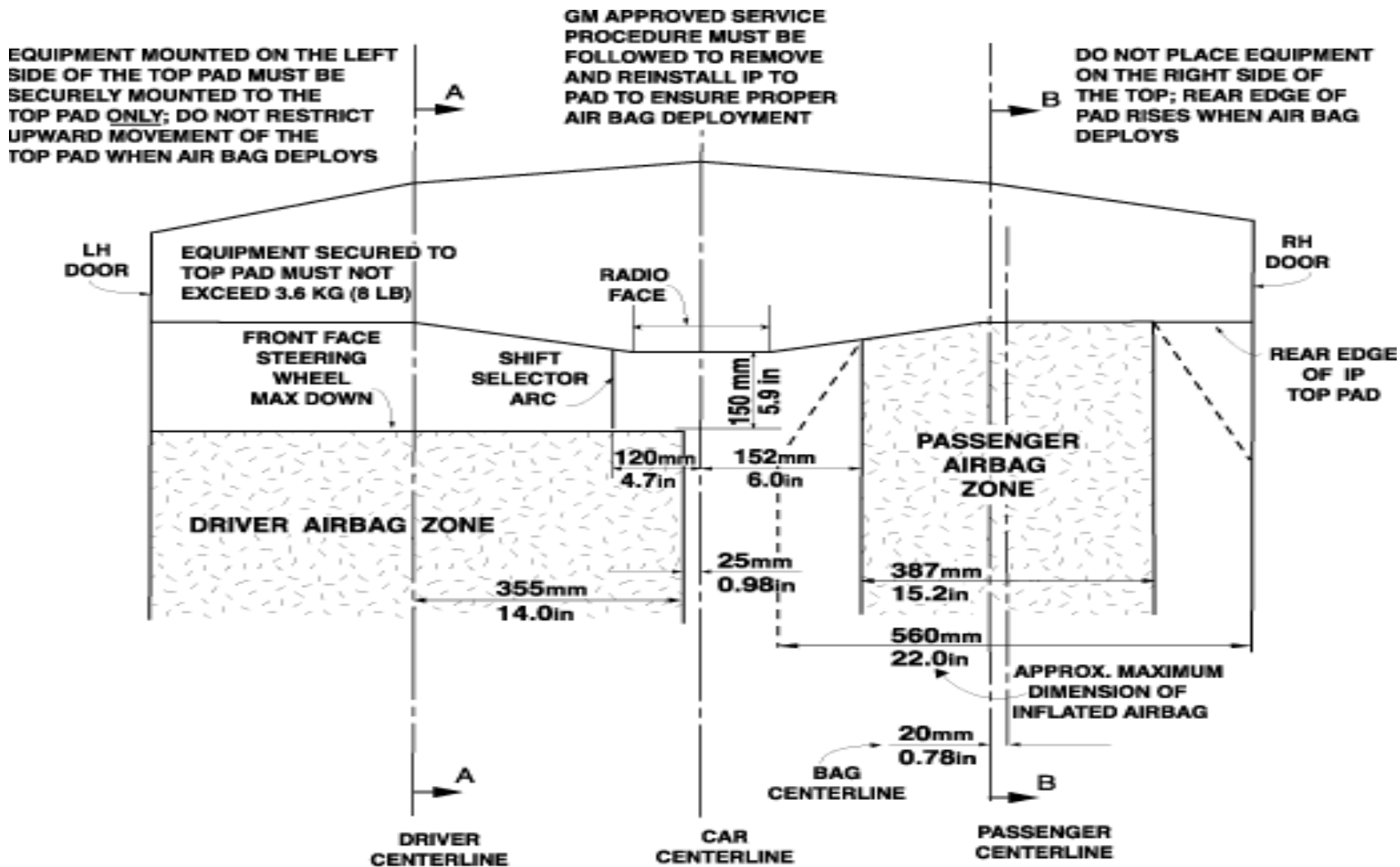



FRONT COMPARTMENT PLAN VIEW

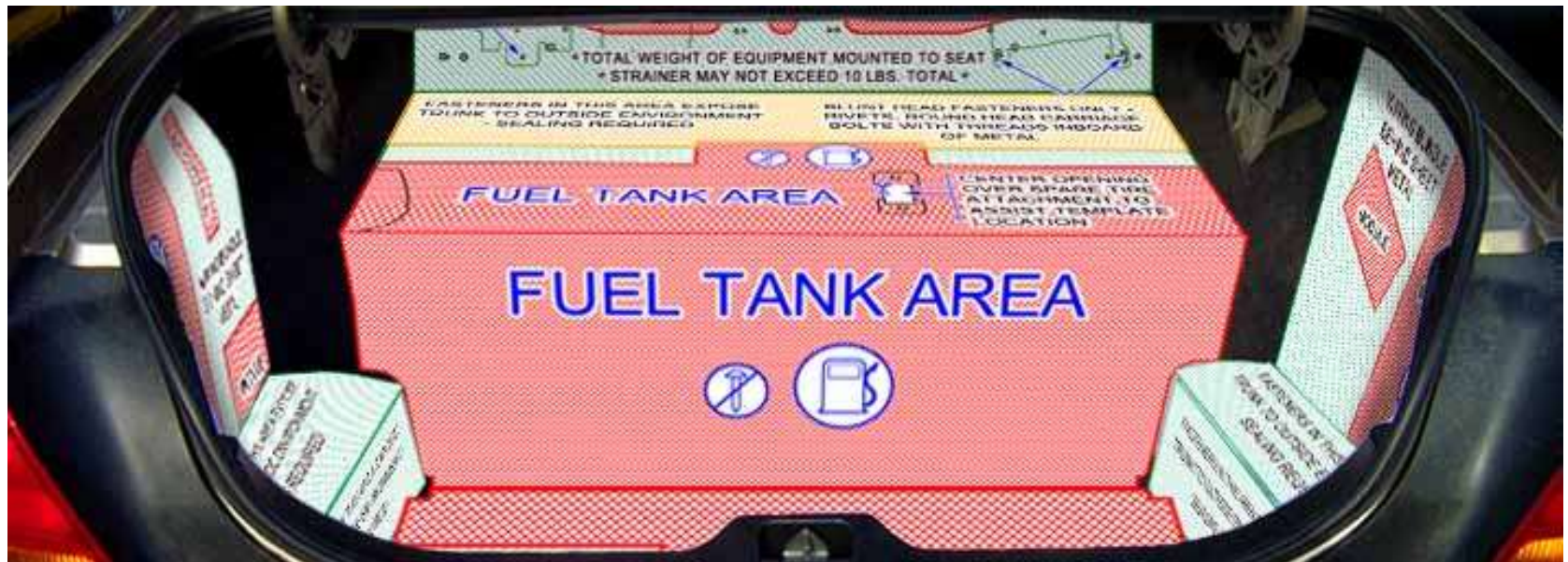

Vehicle Trunk



LEGEND

-  **NO FASTENERS ALLOWED**
-  **BLUNT HEAD FASTENERS ONLY**
rivets, round head carriage bolts with threads inboard of sheet metal
-  **FASTENERS ALLOWED**
limit fastener protrusion beyond equipment to a minimum



Vehicle Trunk

turn dimensions ON

front of vehicle
↕
rear of vehicle

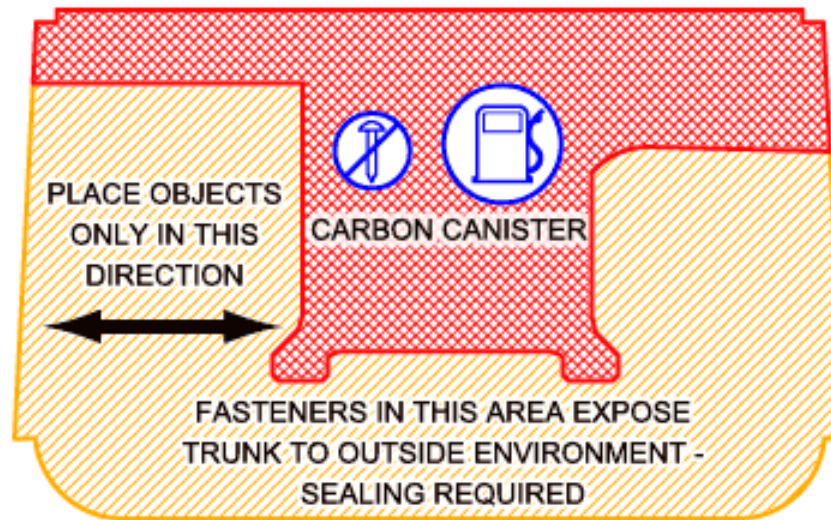

Vehicle Trunk



Fire Extinguisher



Fire Extinguisher

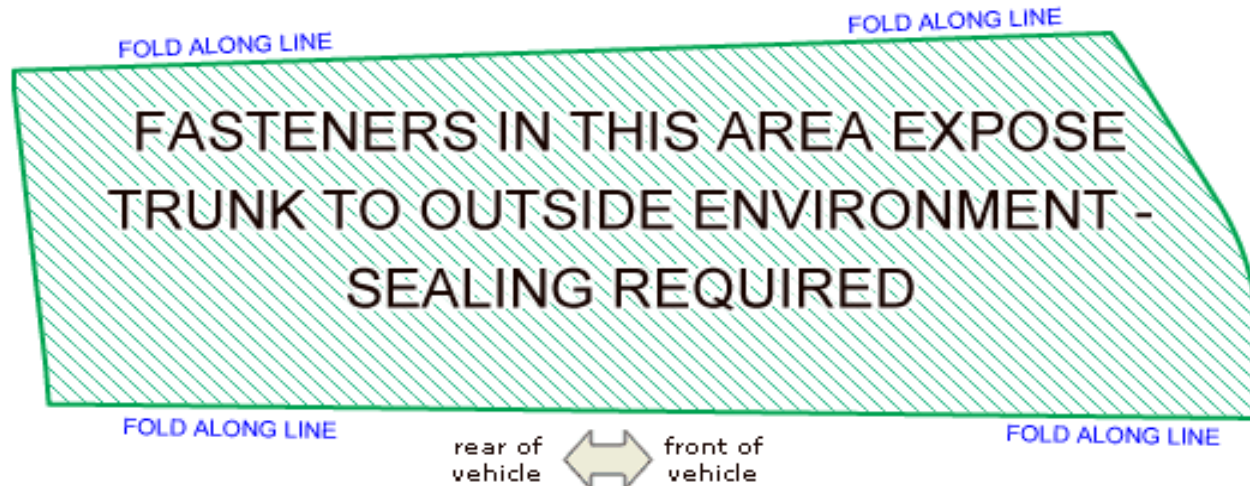

Weapons Release / Shotgun Rack



Weapons Release / Shot gun Rack

- Concerns are:
- Placement of Unit
- Ease of operation
- Proper mounting solution for application
- Proper hardware
- Delay Timer



Weapons Release / Shot gun Rack / Trouble Shooting

- Delay Timer ?
- Coil Short ?
- Proper Fit ?
- Loose Hardware ?
- Wiring and connections ?
- Momentary Switch ?



Vehicle Partitions / Prisoner Compartments



Emergency Vehicle Training

Vehicle Partitions / Prisoner Compartments

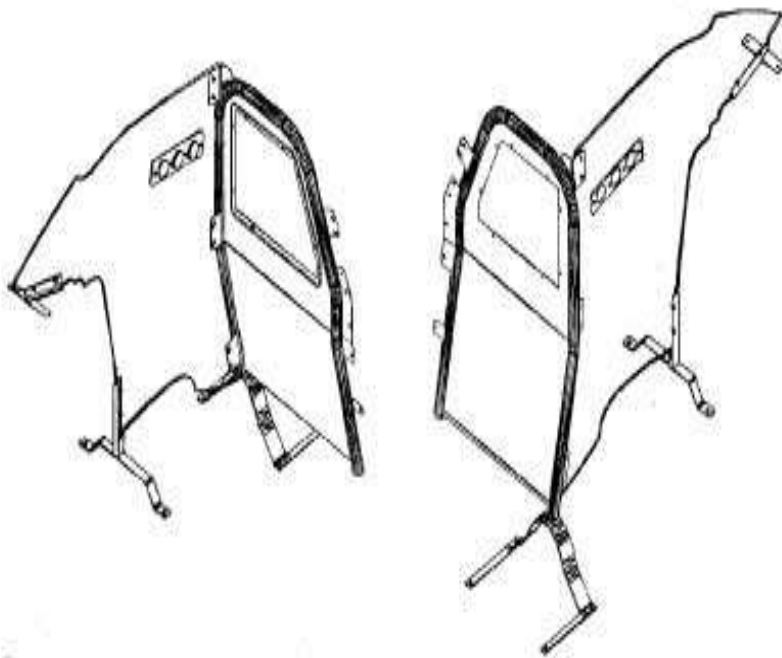

Vehicle Partitions / Prisoner Compartments

- Use factory supplied hardware / Do Not Substitute!
- Follow Manufactures Installation Instructions!
- Take care when drilling or cutting !
- Be sure to disconnect the battery when welding
- Do not weld or modify the boran steel X-bar



Push Bumpers



Push Bumpers

- Interference with Air Bag Deployment
- Vehicle Modifications, Ride Height should be checked
- Additional weight may affect vehicle handling
- Different push bumper designs may each have different deformation characteristics in a crash situation that may or may not affect the deployment of air bags. Without the benefit of crash tests on vehicles equipped with push bumpers (there are a number of different styles available), it is the opinion of Ford Motor Company that installation of some push bumpers could affect the timing of the air bag deployment. Use of a push bumper that mounts solely to the vehicle's bumper should not have a significant effect upon air bag deployment.



Plastic Seats / Floor Liners



Plastic Seats / Floor Liners

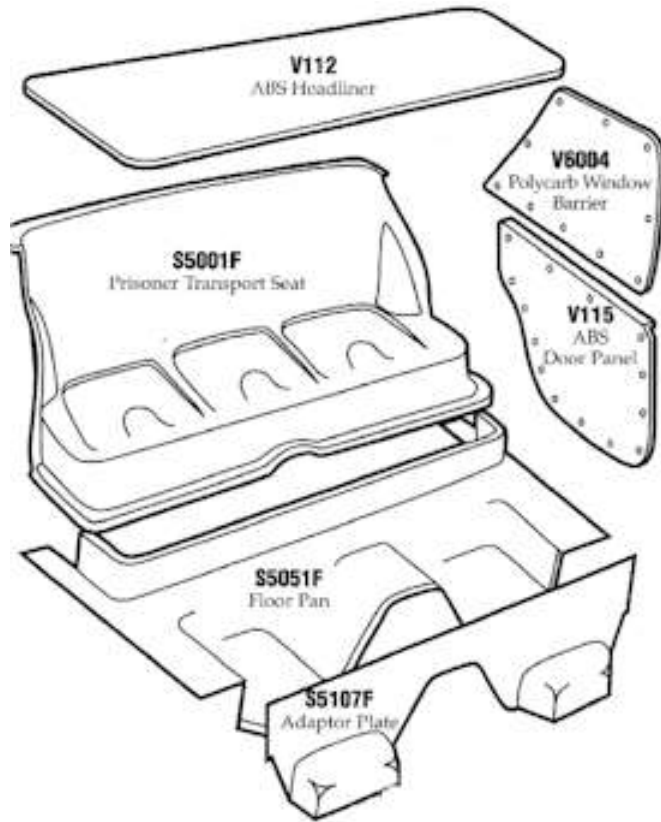

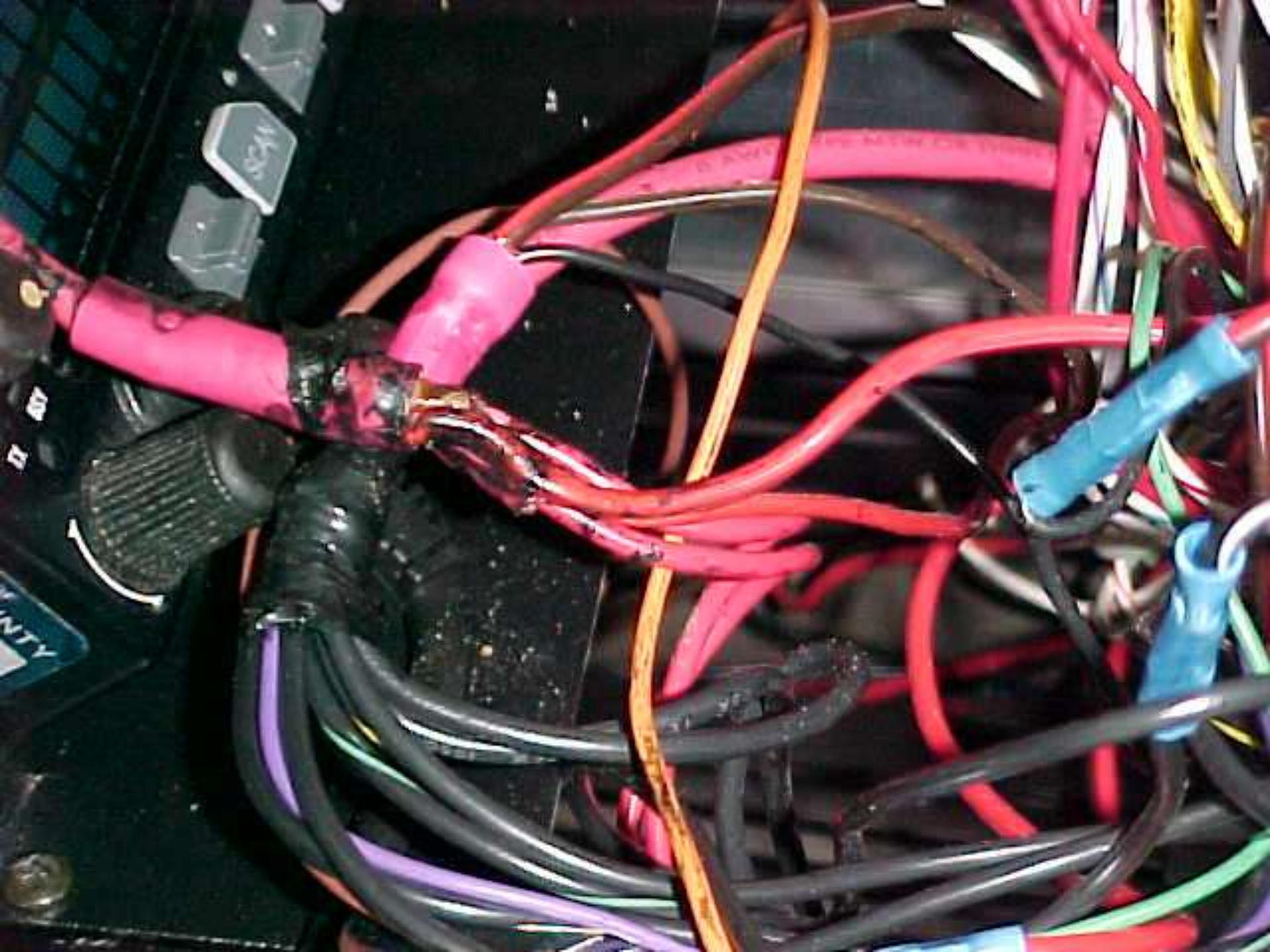



Contact Information

- A J Morganelli
- 386-738-3669 office
- AJ@TeamMorganelli.com
- www.copcartoys.com
- www.evtcc.org

